

MIGRATION SOLUTIONS

SLC 500 CONTROLLER

Representing a major capital investment, automation systems are instrumental to the success of your company. That's why Rockwell Automation stands behind the hardware and software it sells. This unwavering commitment to supporting your automation investments includes unmatched product longevity, continuous upgrades to current products, and worldwide service and support.

Rockwell Automation also develops new products based on a well-thought-out migration plan – one that takes into account both backward compatibility and future technology – so you can best leverage your investments in knowledge and equipment when the time comes to migrate.

And when you want to migrate, you need to work with a supplier that has the technical, project management, and industry expertise to partner with you on a upgrade strategy that will help you maximize your competitive advantage in the years ahead. Rockwell Automation and its partners will work out the right plan that is comfortable for you and that fits your budget.

WE CAN GET YOU FROM HERE...

- Ladder programming
- Basic Motion Control
- PID Instructions
- Structured Data Table Addressing

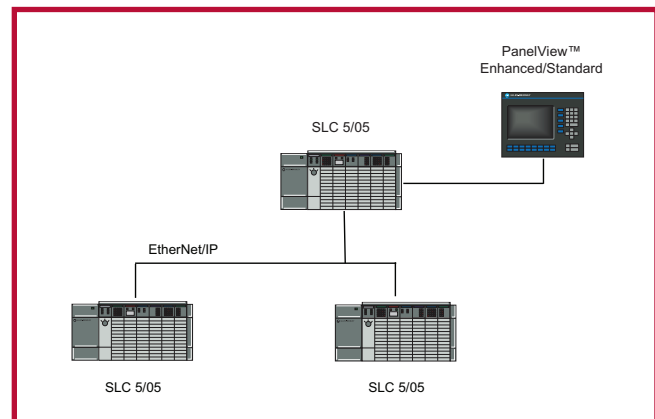

...TO HERE

- Choice of Rockwell Automation programming languages
- Tag Based Addressing
- Re-use of engineering practices to reduce development time and costs
- Maximizing returns from existing assets through greatly improved control and monitoring
- Single environment for integrated motion, process and safety for total plant control

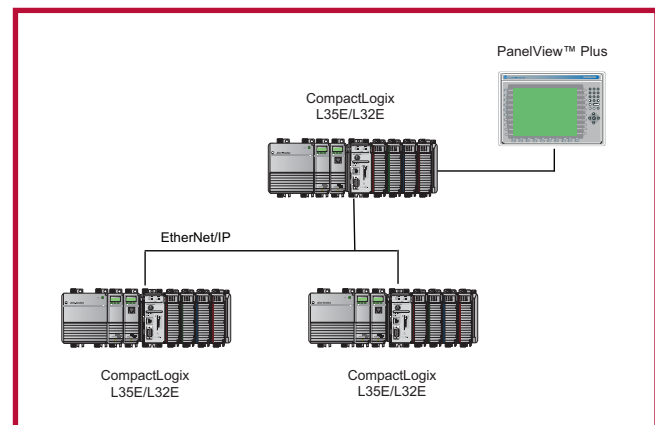

WE HAVE A PLAN

ALL AT ONCE OR STEP-BY-STEP

STEP 1. OPERATOR INTERFACE REPLACEMENTS

Graphic Conversion Utilities for PanelView Enhanced, PanelView Standard, and non-Rockwell Automation HMIs not only make operator interface conversion much more cost effective, but give you greater flexibility regarding the final product. This means that you can account for how operators use your equipment and design interfaces that help maximize their productivity. In the end, this will allow you to give your operators the tools they need to get quality product to your customers.

STEP 2. REPLACE CONTROLLERS

Our logic and Tag Database conversion utilities will help you quickly upgrade your programming logic allowing you to take full advantage of a new Rockwell Automation MicroLogix, ControlLogix, or ControlLogix controllers. This means if and when your manufacturing strategy requires additional performance, we can dovetail a migration plan to your specific needs.

Migration Examples:

- SLC 5/05 (Ethernet/IP) to CompactLogix (shown)
- SLC 5/05 (Ethernet/IP) to ControlLogix
- SLC 5/04 (DH+) to ControlLogix
- SLC 5/04 (DH+) to CompactLogix with ControlLogix Gateway
- SLC 5/02, 5/03, 5/04, 5/05 (RIO) to ControlLogix
- SLC 5/03 (DH-485) to CompactLogix
- SLC 5/03 (DH-485) to MicroLogix 1500
- SLC 5/03 DF1 Master/Slave to CompactLogix DF1 Master and MicroLogix Slave
- SLC 5/03 DF1 Master/Slave to DF1 MicroLogix Master and MicroLogix Slave

STEP 3. KEEP OR REPLACE YOUR CURRENT I/O, WHATEVER'S RIGHT FOR YOU

I/O cross reference documentation assures correctness and provides back-up for future troubleshooting or diagnostics. I/O replacement represents a large investment, various options allow you to keep your current I/O, replace it in individual sections, or all at once. Whatever's right for you and your budget.

STEP 4. OTHER ENHANCEMENTS THAT WOULD INCREASE THE PERFORMANCE OR MAINTAINABILITY OF YOUR EQUIPMENT

Because Rockwell Automation is a comprehensive supplier, we can help in other areas as well. We carry everything from sensors to motor control centers, so we can discuss all your needs. But it does not stop there. We have a worldwide service group that can do the migration, assist and train your operators or provide the maintenance services once it's complete. We can also review your network needs and review asset management for your entire plant.

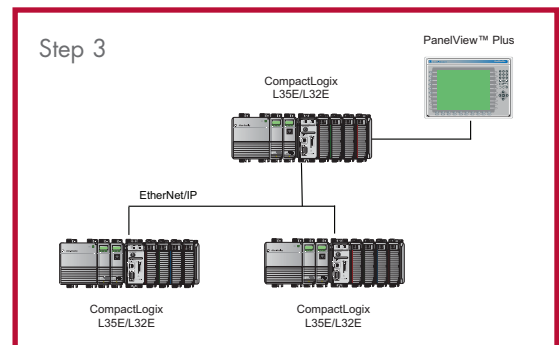
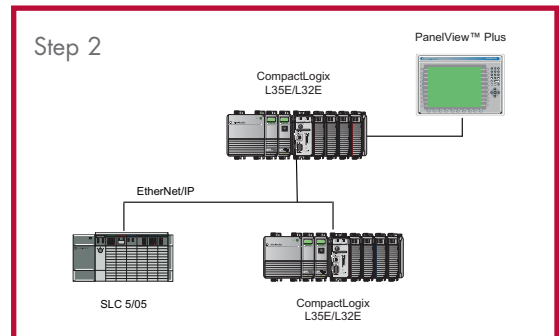
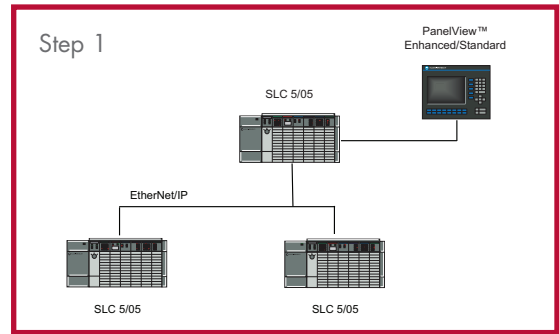

Rockwell Automation provides many migration options. If you want or need to upgrade your systems all at once, we have the expertise and resources to get the job done quickly to minimize your potential loss of production. If you want to schedule migration service over time, we will work with you to create a plan that fits both your schedule and budget. In the end, we work with you to ensure that your migration investments better serve your customers and return a profit. Rockwell Automation has the technical, project management, and industry knowledge to make sure your migration project does what it's supposed to do...make you money.

All trademarks and registered trademarks are the property of their respective companies.

LISTEN. THINK. SOLVE. SM

**Rockwell
Automation**