

SR3000 Snubber Resistor Braking Kits for 230 V and 460 V GV3000/SE Drives

230 VAC Model Number 2SR20450

460 VAC Model Number 2SR40700

Instruction Manual D2- 3401



ATTENTION: Only qualified electrical personnel familiar with the construction and operation of this equipment and the hazards involved should install, adjust, operate, and/or service this equipment. Read and understand this manual and other applicable manuals in their entirety before proceeding. Failure to observe this precaution could result in severe bodily injury or loss of life.

The products described in this manual are manufactured or distributed by Reliance Electric Industrial Company.

Product Description

The SR3000 Snubber Resistor Braking Unit connects to 230 V GV3000/SE drives of 15 HP or larger and 460 V GV3000/SE drives. It is used to dissipate the power regenerated by the motor during rapid deceleration or during overhauling load conditions.

The regenerated energy is normally consumed, as shown in figure 1, by mechanical loss, by the motor, and by the drive. The remaining energy is stored in the drive's DC bus capacitor. If the remaining energy causes the capacitor voltage to rise above the normal operating range, the Braking Unit will discharge the regenerated energy before the drive voltage becomes excessive. Two units can be connected (paralleled) to provide increased watt dissipation.

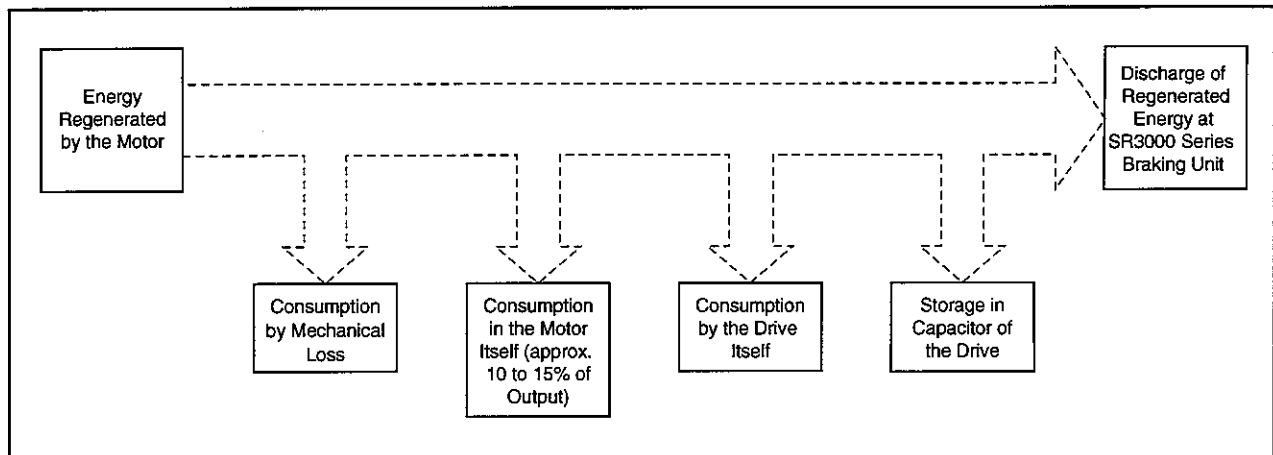

Figure 1 - Dissipation of Energy Regenerated by the Motor

GV3000/SE and Reliance are trademarks of Rockwell Automation.
© 1997 Rockwell International Corporation.

Overload protection of the snubber resistor is provided via the terminal strip I/O on the faceplate for connection to a user-supplied protection circuit and by the status LEDs. If an overload fault occurs, the Braking Unit will shut down. Figure 2 shows the faceplate of the Braking Unit with the terminal strip cover removed. Refer to table 1 for a description of the LEDs.

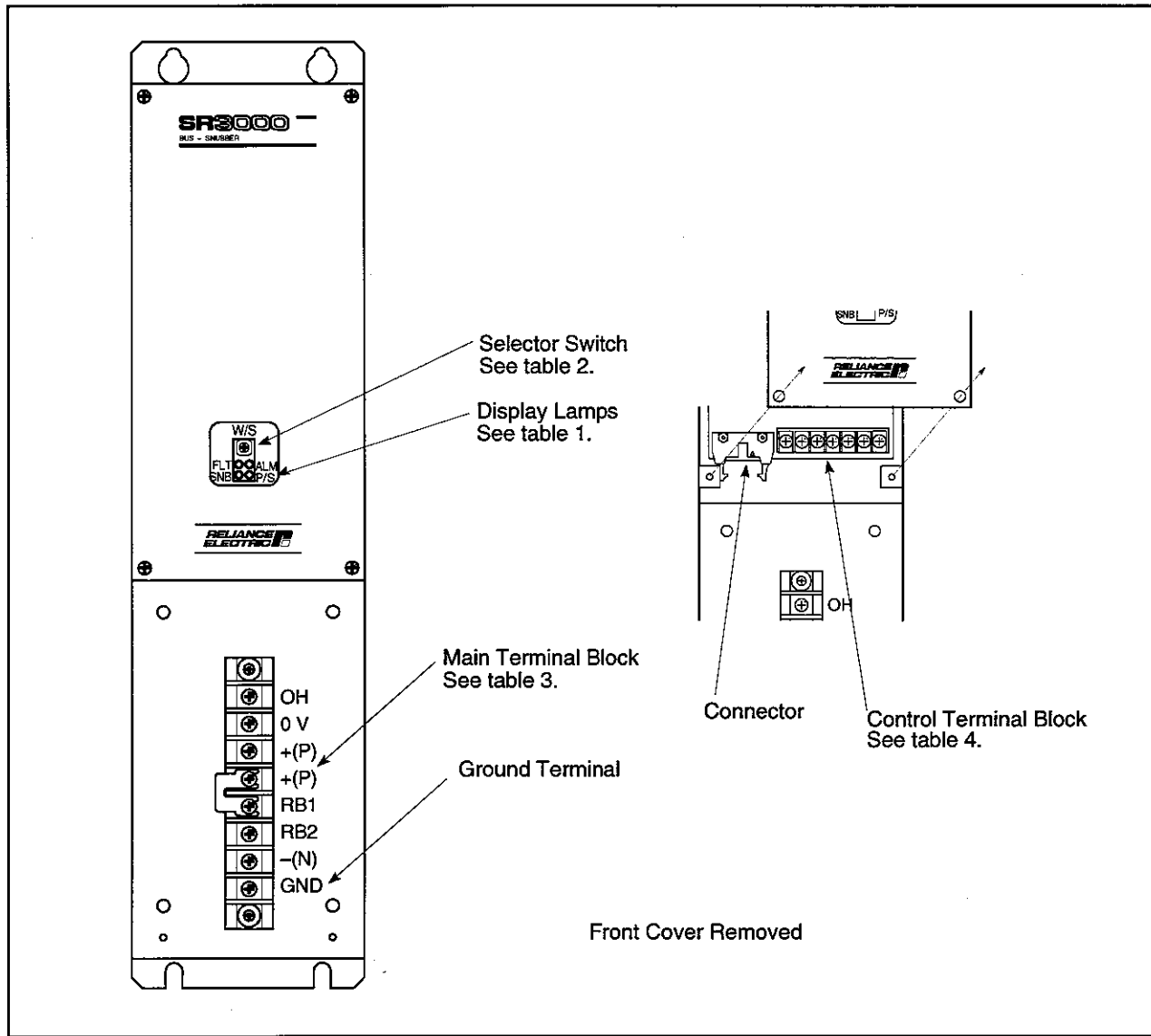

Figure 2 - Front Panel of the SR3000 Snubber Resistor Braking Unit

Table 1 - LED Descriptions

LED	Description
P/S	The P/S LED will turn on when DC bus voltage of the drive is charged and DC power is supplied to the Braking Unit.
SNB	The SNB LED will turn on to indicate that regenerated power is being discharged.
FLT	The FLT LED will turn on if the overload condition on the Braking Unit occurs.
ALM	The ALM LED will turn on at approximately 80% of the Braking Unit overload detection level.

Installing the Snubber Resistor Braking Unit



ATTENTION: DC bus capacitors retain hazardous voltages after input power has been disconnected. After disconnecting input power, wait five (5) minutes for the DC bus capacitors to discharge and then check the voltage with a voltmeter to ensure the DC bus capacitors are discharged before touching any internal components. Failure to observe this precaution could result in severe bodily injury or loss of life.

ATTENTION: The user is responsible for conforming with all applicable local, national, and international codes. Failure to observe this precaution could result in damage to, or destruction of, the equipment.

Installing the Braking Unit consists of the following steps:

- Mounting the Braking Unit
- Selecting an external resistor, if required
- Installing an external resistor, if required
- Setting the snubber resistor overload detection level
- Wiring the Braking Unit

Mounting the Braking Unit

Refer to the dimensions in figure 3 and use the following guidelines when mounting the Braking Unit:

- Leave a minimum of 50 mm (2 in) clearance between the Braking Unit and the drive.
- Leave a minimum of 80 mm (3.1 in) clearance above and below the Braking Unit.
- If two Braking Units are installed in parallel, leave a minimum of 50 mm (2 in) clearance between each unit.
- Do not install the Braking Unit under the drive.

Grounding the Braking Unit

Use the following steps to ground the Braking Unit:

- Remove the front cover from the front panel.
- Run a suitable equipment grounding conductor unbroken from the Braking Unit ground terminal to the earth ground. See figure 2 for the location of the Braking Unit ground terminal.
- Re-attach the front cover.

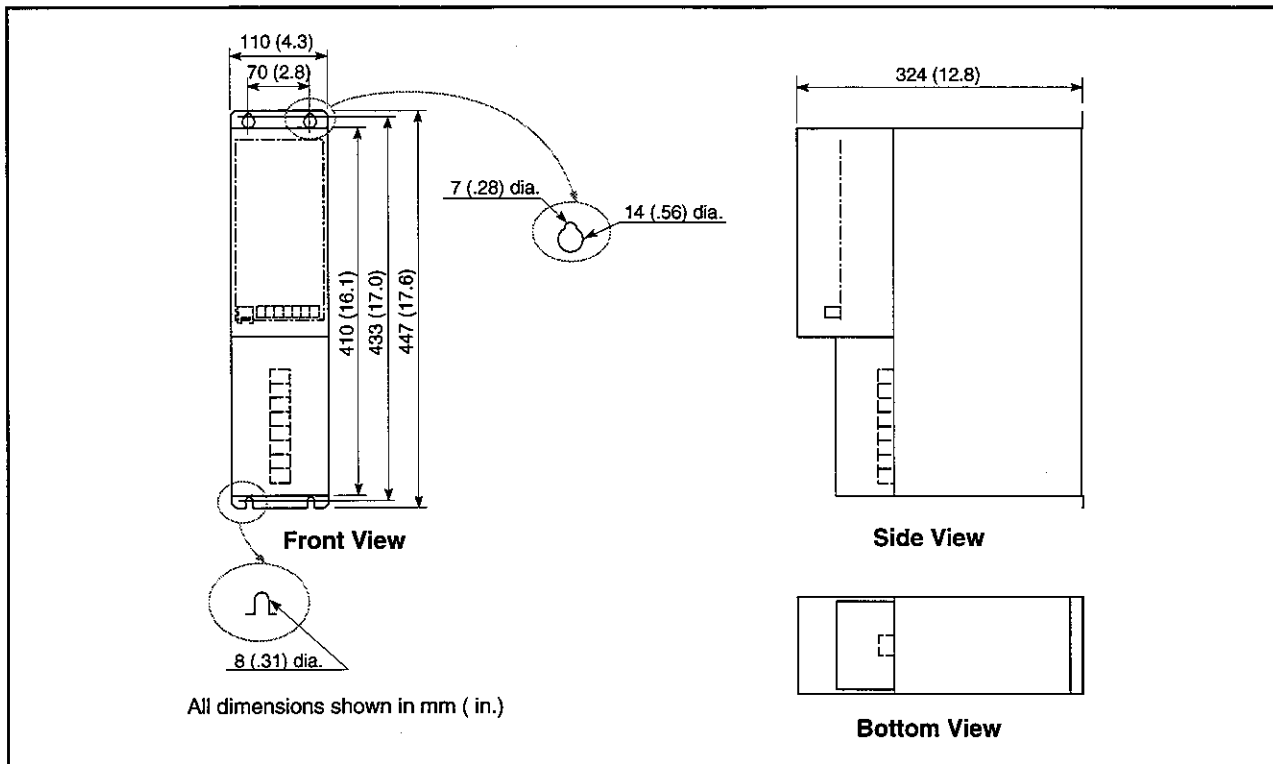

Figure 3 - Model 2SR20450 and Model 2SR40700 Braking Unit Mounting Dimensions

Selecting an External Resistor, If Required



ATTENTION: When an external resistor is installed, first disconnect the power to the drive and wait five (5) minutes for the DC bus capacitors to discharge. Then check the voltage with a voltmeter to ensure the DC bus capacitors are discharged before touching any internal components. Failure to observe this precaution could result in severe bodily injury or loss of life.

If it is possible for the drive to regenerate more energy than the Braking Unit's built-in resistor can dissipate (The internal energy dissipation capability of Model 2SR20450 is 450 W and that of 2SR40700 is 700 W), you must install an external resistor. The SR3000 Braking Unit can continuously dissipate the regenerated energy shown in table 2 by adding an external resistor. When two Braking Units are installed in parallel (to increase watt dissipation), install external resistors having the same capacity in both units. In this case, the watt dissipation value shown in table 2 must be doubled.

Use the following procedure to select a resistor:

- Step 1. Calculate the regenerated power P_{ave} from the load and pattern of operation.
- Step 2. Obtain the watt dissipation of the resistor P_d , deducting 15% of rated output of the motor (as the consumption by the machine or the motor) from the P_{ave} value calculated in step 1 above.
- Step 3. Select the resistor watt dissipation P_r as follows in consideration of heat generated by the resistor.

$$P_r [W] = 3 \text{ to } 4 \times P_d$$

An example of calculating the regenerated power in the case of repeated operation under inertial load is shown as "R" in figure 4 and its average power P_{ave} is calculated as follows:

$$P_{ave} [W] = 1/2 \times P_p \times t/T$$

where t (regeneration time) should be less than or equal to 0.5 seconds for the built-in resistor.

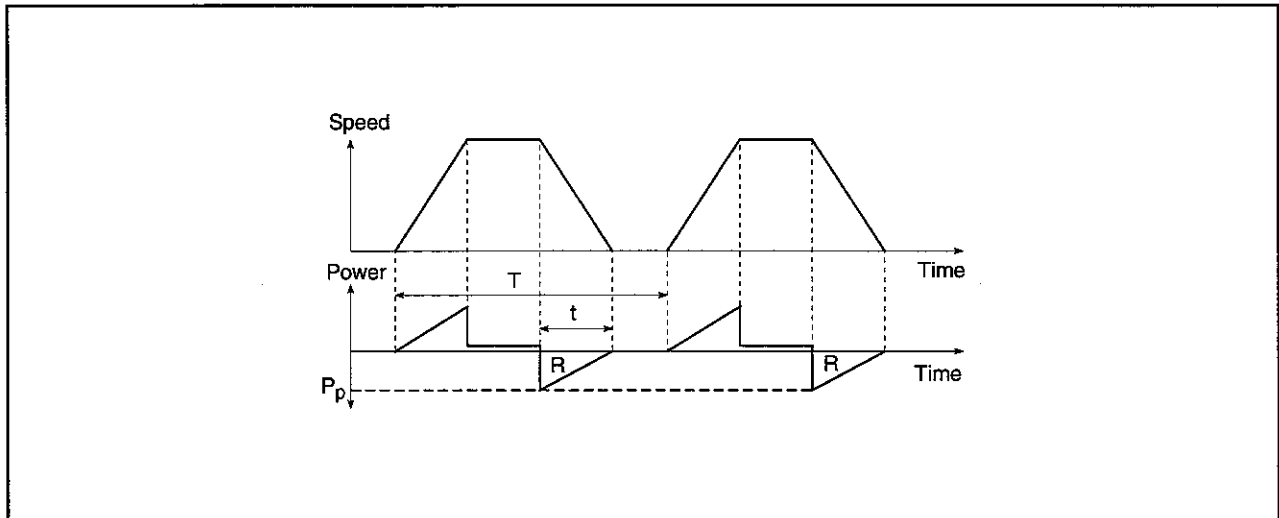

Figure 4 - An Example of Repeated Operation Under Inertial Load

Installing the External Resistor, If Required

To install the selected external resistor, first remove the jumper between terminals +(P) and RB1. Install the external resistor between terminals +(P) and RB2. See figure 5, 6, 7 or 8. Refer to table 3 and 4 for a description of the terminal strip connections. Note that the internal resistor is not used if the external resistor option is selected.

The cable length for connecting the external resistor should not exceed 5 m (16.4 feet).

Setting the Snubber Resistor Overload Detection Level

The W/S switch on the faceplate is used to select the maximum watt dissipation level of the selected resistor (built-in or external). Set the switch to match the dissipation capacity P_d of the resistor. If the resistor rating falls in between the switch setting levels, select the lower of the two settings. If you are connecting two units in parallel, both units must be set to the same switch setting. Table 2 shows the overload detection level settings. For assistance in calculating the appropriate resistor value, refer to Selecting a Resistor.

Table 2 - W/S Switch Settings for Braking Unit Overload Detection Level

Resistor Used	W/S Switch Setting	Watt Dissipation ²		Minimum Ohm Rating		Maximum Ohm Rating	
		2SR20450	2SR40700	2SR20450	2SR40700	2SR20450	2SR40700
External Resistor	1	500	800	3.9	7.5	33	60
	2	550	900	3.9	7.5	33	60
	3	600	1000	3.9	7.5	33	60
	4	1400	2500	3.9	7.5	33	60
	5	1600	3000	3.9	7.5	22	30
	6	4000	7500	3.9	7.5	11	15
	7	8000	15000	3.9	7.5	5	10
Built-in Resistor	0 ¹	450	700	N/A	N/A	N/A	N/A

¹ Factory-default setting.

² Watt dissipation of the external resistor shows the value set as calculated in Selecting a Resistor.

Wiring the Braking Unit

When only one Braking Unit is installed, install wiring between the drive and the Braking Unit according to figure 5 for 230 V GV3000/SE drives or figure 7 for 460 V GV3000/SE drives.

If two Braking Units are paralleled, install wiring according to figure 6 for 230 V GV3000/SE drives or figure 8 for 460 V GV3000/SE drives.

The recommended wire size for the connection between the drive and the Braking Unit is 8 mm² (AWG 8), and the cable length should not exceed 2 m (6.5 feet).

A user-supplied interlocking circuit consisting of two relays and a pushbutton should be provided as shown in the following wiring diagrams.

When external resistors are used, be sure to install a Resistor Overheat Protection Kit for each braking unit at the largest heat generating portion to protect the resistor from burning. For wiring thermostat of this kit, use 200°C (392°F) / 600 V UL wire. (Keep the wiring away from the resistor as far as possible.) Table 5 lists recommended bus line fuses.

All input/output connections to the Braking Unit are made at the terminal strip. Remove the front cover and route the cable through the hole at the bottom of the cover. Connect to the terminal strip as described in table 3 and table 4. Tighten the terminals to 1.2 N·m (11 lb-in). Replace the cover after all of the terminal strip connections have been made. Do not touch the terminals while the Braking Unit is connected to a live DC bus.



ATTENTION: Connect 2SR20450 to 230 V GV3000/SE drive and 2SR40700 to 460 V GV3000/SE drive. Connecting 2SR20450 to 460 V GV3000/SE drive and connecting 2SR40700 to 230 V GV3000/SE drive could result in damage to, or destruction of, the Braking Units.

When and How to Connect Parallel Units

To connect two Braking Units in parallel, connect the CN1 connectors of the both Braking Units with the CN1-Cable MC-B6004 (see table 8) which is available as an optional item. See figures 6 and 8 and table 8.

Connecting 2SR20450 to 230 V GV3000 drive

It is recommended to use one 2SR20450 Braking Unit for 15 HP to 40 HP drives, and to connect two Braking Units in parallel for 50 HP, 60 HP and 75 HP drives. A single SR3000 Braking Unit has an instantaneous handling capacity up to 40 kW and a continuous handling capacity up to 8 kW.

For drives larger than 40 HP, a single Braking Unit can be used by connecting an external resistor, if no rapid deceleration of the motor is expected. But if rapid deceleration is a consideration, it is recommended that the parallel Braking Units be used. The instantaneous handling capacity for two parallel Braking Units is up to 80 kW.

For drives of 100 HP or larger, two parallel units are recommended. But in this case, deceleration of the motor may be limited.

Connecting 2SR40700 to 460 V GV3000/SE drive

It is recommended to use one Braking Unit for drives up to 75 HP drives, and to connect two Braking Units in parallel for 100 HP, 125 HP and 150 HP drives. A single SR3000 Braking Unit has an instantaneous handling capacity up to 75 kW and a continuous handling capacity up to 15 kW.

For drives larger than 75 HP, a single Braking Unit can be used by connecting an external resistor, if no rapid deceleration of the motor is expected. But if rapid deceleration is a consideration, it is recommended that the parallel Braking Units be used. The instantaneous handling capacity for two parallel Braking Units is up to 150 kW.

For drives of 200 HP or larger, two parallel units are recommended. But in this case, deceleration of the motor may be limited.

Table 3 - Main Terminal Strip Connections

Terminal Name	Faceplate Symbol	Description
OVERHEAT	OH 0V	This terminal is used to input an overtemperature signal from the thermostat of a Resistor Overheat Protection Kit (M/N MB-B5071) if the external resistor overheats. Connect to the external resistor's thermostat.
DC Supply	+(P) -(N)	This terminal is used to input the DC bus voltage. Connect to the + and - DC bus terminals on the GV3000/SE drive or the SP500 drive.
RB	RB1 RB2	These terminals select which resistor will be used to dissipate energy. <ul style="list-style-type: none"> ● If the built-in resistor is used, leave the jumper bar connected to +(P) and RB1 as shipped from the factory. RB2 should be kept open. ● If an external resistor is used, connect the resistor between +(P) and RB2. RB1 should be kept open.
GND	GND	Ground (earth) terminal.

Table 4 - Control Terminal Strip Connections

Terminal Name	Faceplate Symbol	Description
24VI	24V	This terminal is a 24V isolated power supply. The output current is 0.1A.
FAULT	FLT	This terminal provides an output fault signal if an overload condition occurs. The open collector signal will be on when any fault occurs, and the Braking Unit will shut down. This terminal should be tied in series with the function loss terminals (terminals 16 and 20 on the GV3000/SE drive or terminals 10 and 11 on the SP500 drive.) Output capacity of signal: <ul style="list-style-type: none"> ● Allowable voltage: 12 to 30 V (externally supplied) ● Allowable current: 0.05 A
ALARM	ALM	This terminal provides an output alarm signal when 80% of snubber overload detection level (set by the W/S switch on the faceplate) has been reached. The open collector signal will be on when the alarm level is exceeded. Output capacity of signal: <ul style="list-style-type: none"> ● Allowable voltage: 12 to 30 V (externally supplied) ● Allowable current: 0.05 A
0VI	0V	Signal common.
RESET	RST	This terminal provides a RESET input to clear alarms and faults. Connect RST to terminal 0V to reset the Braking Unit.
EXTERNAL FAULT	EXF	This terminal is used to enter external fault.
0VI	0V	Signal common.

Table 5 - Recommended Bus Line Fuses

	Description	Specification	Vendor	Part No.
FU1, FU2	Fuse	A70P80	Gould	-
	Holder	P243C	Gould	-

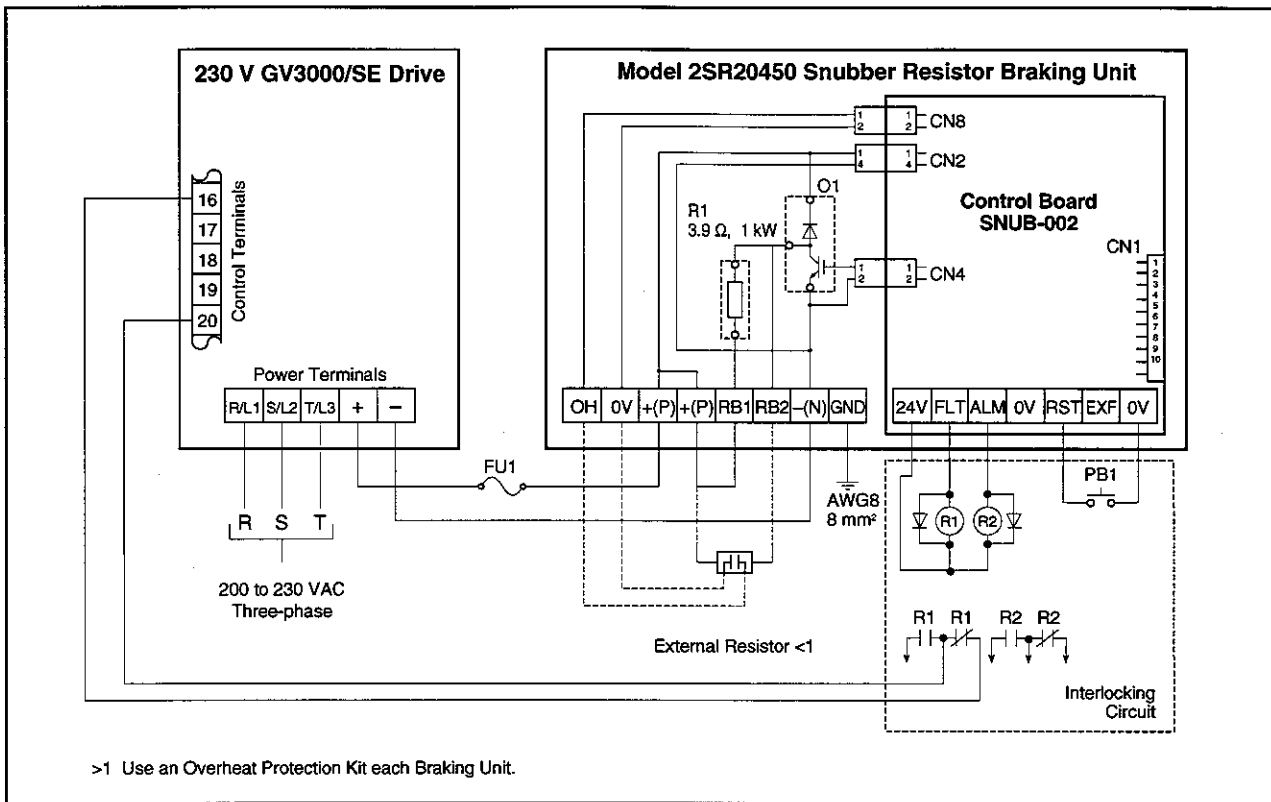

Figure 5 - Wiring Diagram for 230 V GV3000/SE Drives (Connecting One Braking Unit)

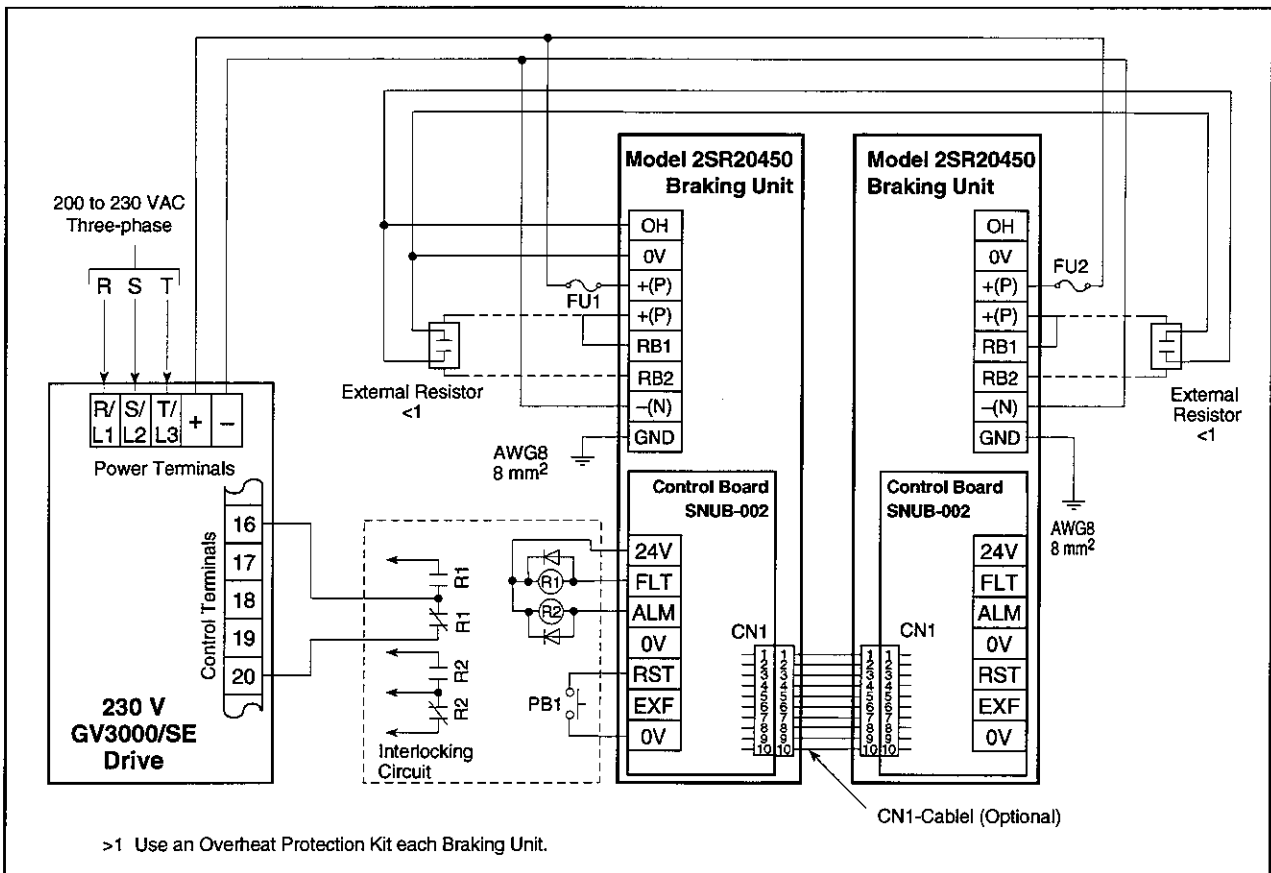

Figure 6 - Wiring Diagram for 230 V GV3000/SE Drives (Connecting Two Braking Units in Parallel)

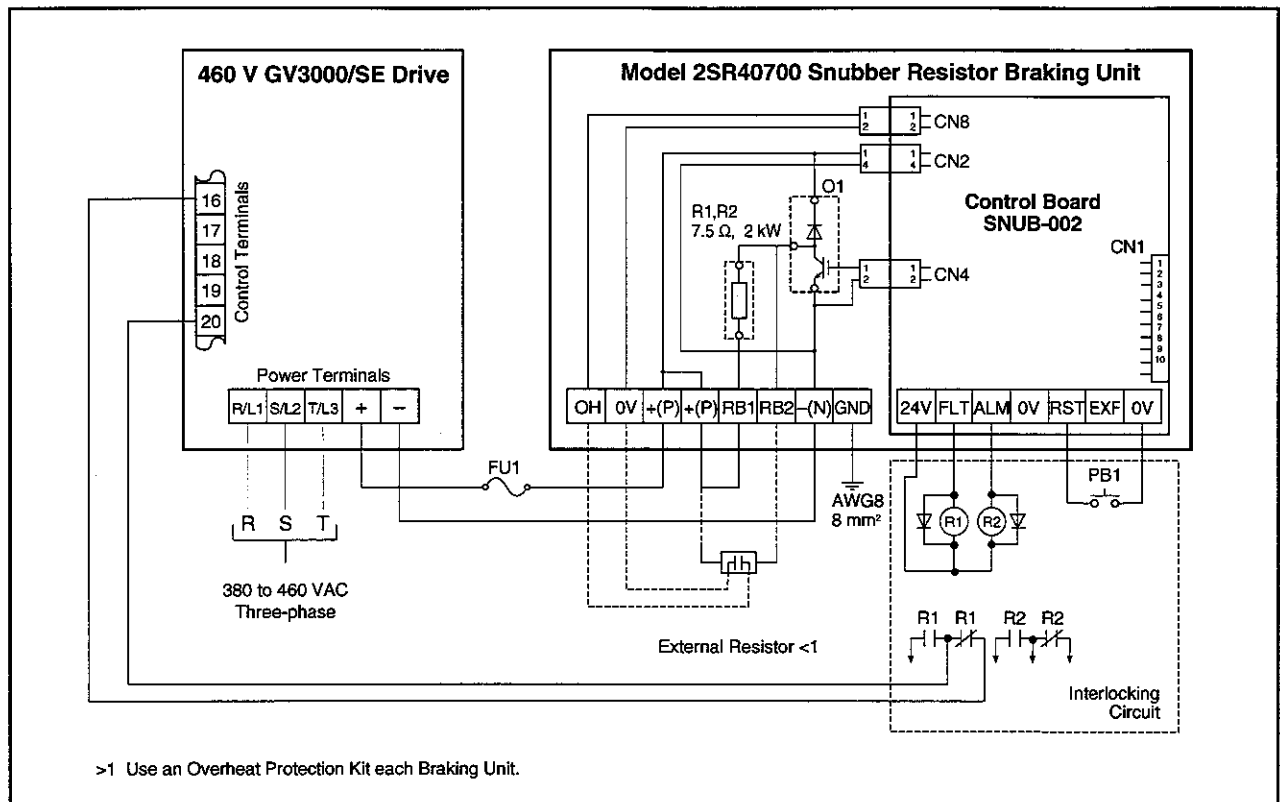

Figure 7 - Wiring Diagram for 460 V GV3000/SE Drive (Connecting One Braking Unit)

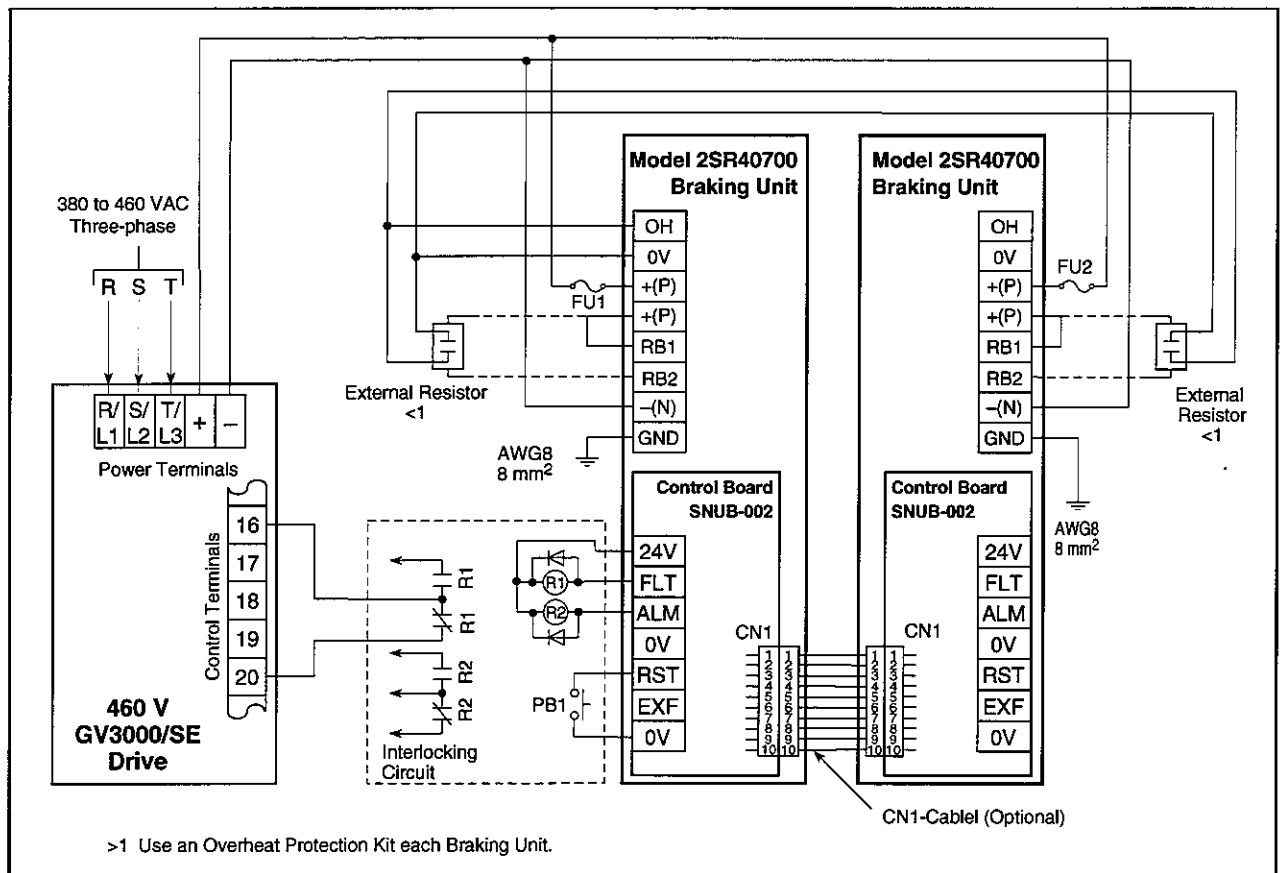

Figure 8 - Wiring Diagram for 460 V GV3000/SE Drives (Connecting Two Braking Units in Parallel)

Technical Specifications

Table 6 - Braking Unit Specifications

Number of Braking Units Connected		One Unit		Two Units Connected in Parallel	
Model Number		2SR20450	2SR40700	2SR20450	2SR40700
Voltage Class		150 ~ 430	300 ~ 800	150 ~ 430	300 ~ 800
Output	Rated Output (kW) (using external resistor)	8	15	8 x 2	15 x 2
	Instantaneous Maximum Output (kW)	40	75	40 x 2	75 x 2
Turn-On Voltage		400 ± 12 VDC	750 ± 12 VDC	400 ± 12 VDC	750 ± 12 VDC
Regeneration Discharge	Resistor Capacity (W)	1000	2000	1000 x 2	2000 x 2
	Continuous Handling Capacity (W)	450	700	450 x 2	700 x 2
	Instantaneous Maximum Handling Capacity (kW) (within 0.5 seconds)	40	75	40 x 2	75 x 2
	Minimum Resistance (Ohm)	3.9	7.5	3.9	7.5
Protection Functions		Overcurrent			
Alarm and Fault Signals		Open collector, two outputs (allowable voltage 12 to 30 VDC, allowable current 0.05 A). To be used as an alarm/fault signal for overload conditions.			
Cooling Method		Forced ventilation with DC brushless fan.			
Environment	Location	In control cabinet (free from corrosive or dangerous gas).			
	Ambient Temperature	Operating: -10° to 55°C (14° to 131°F) Storage: -40° to 65°C (-40° to 149°F)			
	Ambient Humidity	5 to 95%, non-condensing			
	Elevation	1000 meter or lower above sea level			
	Vibration	Less than 1 G (25 Hz)			
	Shock	Less than 2 G			
Weight		8 kg	11.3 kg	8 kg	11.3 kg

Replacement and Optional Parts

Table 7 - Replacement Parts

Description	Part Number	Required Quantity	
		2SR20450	2SR40700
Control Board SNUB-002 230 V	827709 (230 V)	1	-
Control Board SNUB-002 460 V	827709 (460 V)	-	1
IGBT Transistor	529208	1	1
Current Sensor	556072	1	1
Snubber Capacitor	459604	1	1
Snubber Diode	502505	1	1
Snubber Resistor	429052	1	1
DC Brushless Fan (24 VDC)	373653	1	1
Regenerative Resistor	429723	1	-
Regenerative Resistor	429724	-	2

Note : Specify 230 V or 460 V for the voltage of the braking unit when you order a control board SNUB-002 since the board is different for 230 V or 460 V though the part number is the same.

Table 8 - Optional Items

Description	Model Number	Part Number
CN1-Cable	MC-B6004	171127

External Resistors

Table 9 - External Resistor Specifications

Reliance Part Number	Model Number	Continuous Watt Dissipation (W)	Rated Power (kW)	Resistance (Ohm)	Weight (kg (lbs.))
428302	85161/1512	400	1.2	1.5	2.2 (4.9)
428301	85161/720	600	0.7	0.7	3.5 (7.2)

Table 10 - Model MB-B5071 Coil Resistor Overheat Protection Kit

Model Number	Overheat detection level
MB-B5071	130°C (266°F)

Table 11.1 - Examples of External Resistor Combinations for 2SR20450

Composite Resistors Ohm / Watt	Resistor Circuit Connections			Continuous Watt Dissipation (kW)	Instantaneous Watt Dissipation (kW)	Setting of W/S Switch
	In Series	In Parallel	Total Number			
1.5 / 1200	3	0	3	1.2	35	4
0.7 / 2000	6	0	6	4.0	38	6

Table 11.2 - Examples of External Resistor Combinations for 2SR20700

Composite Resistors Ohm / Watt	Resistor Circuit Connections			Continuous Watt Dissipation (kW)	Instantaneous Watt Dissipation (kW)	Setting of W/S Switch
	In Series	In Parallel	Total Number			
1.5 / 1200	5	0	5	2.0	75	4
0.7 / 2000	11	0	11	6.6	73	6

Reliance Electric / 24703 Euclid Avenue / Cleveland, Ohio 44117 / (216) 266-7000

 **Rockwell** Automation

Reliance Electric