

# Double Pole Circuit Breaker Kit for Non-Regenerative MinPak Plus DC Drives

Model Numbers 14C210, 14C211, 14C212, and 14C213

Instruction Manual D2-3385



**ATTENTION:** Only qualified electrical personnel familiar with the construction and operation of this equipment and the hazards involved should install, adjust, operate, and/or service this equipment. Read and understand this manual and other applicable manuals in their entirety before proceeding. Failure to observe this precaution could result in severe bodily injury or loss of life.

## Product Description

The standard power on/off circuit breaker on single-phase, non-regenerative MinPak™ Plus DC drives is a single pole, magnetic trip/manual trip unit that provides overcurrent protection for the drive's power devices. The Double Pole Circuit Breaker provides an additional degree of protection by removing all power from the control circuits. When tripped, the Double Pole Circuit Breaker opens both AC input conductors (L1 and L2) between the drive's power devices and drive terminal block 1TB.

The Double Pole Circuit Breaker must match the drive's horsepower and voltage rating, as shown in table 1. Refer to your drive's nameplate for the horsepower rating.

Table 1 – Verifying that the Circuit Breaker Matches the Drive

Drive Model Number	Drive Horsepower and Voltage Rating	Double Pole Circuit Breaker Kit Model Number
14C10, 14C20	1/4 to 3/4 HP @ 115 VAC	14C210
14C11, 14C21	1/2 to 1-1/2 HP @ 230 VAC	14C211
14C12, 14C22	2 and 3 HP @ 230 VAC	14C212
14C13, 14C23	5 HP @ 230 VAC	14C213

The Double Pole Circuit Breaker kit includes the circuit breaker, connecting wires, and the required mounting screws. No other options are needed when using this kit, and no user-supplied parts are required. The contents of the kit are listed in table 2.

Table 2 – Contents of the Double Pole Circuit Breaker Kit

Description	Quantity	Part Number
Double Pole Circuit Breaker	1	65241 -76A , -77A, -56C <sup>1</sup>
Jumper Wire 182	1	608813 -80Y, -80R, -80S <sup>1</sup>
Jumper Wire 52	1	608813 -80V, -80W, -80X <sup>1</sup>
Harness Wire 51/52	1	608813 -81R
Mounting Screw, 6-32 x 1/4	4	601742 -2C
Instruction Manual	1	D2-3385

1. Supplied with model numbers 14C210/14C211, 14C212, and 14C213, respectively

## Installing the Double Pole Circuit Breaker



**ATTENTION:** Do not install modification kits with power applied to the drive. Disconnect, lock out, and tag all sources of incoming AC power to the drive before attempting such installation. Verify that no voltage is present at the drive's AC input terminals, L1/181 and L2/182. Failure to observe this precaution could result in severe bodily injury or loss of life.

**ATTENTION:** The user is responsible for conforming with all applicable local, national, and international codes. Failure to observe this precaution could result in damage to, or destruction of, the equipment.

Refer to your drive instruction manual for help locating and identifying drive components. Refer to figure 1 for wiring information.

To install the Double Pole Circuit Breaker in your non-regenerative MinPak Plus DC drive:

Step 1. Disconnect, lock out, and tag input power to the drive.

Step 2. Remove the drive cover and verify that no voltage is present at the drive's AC input terminals, L1/181 and L2/182.

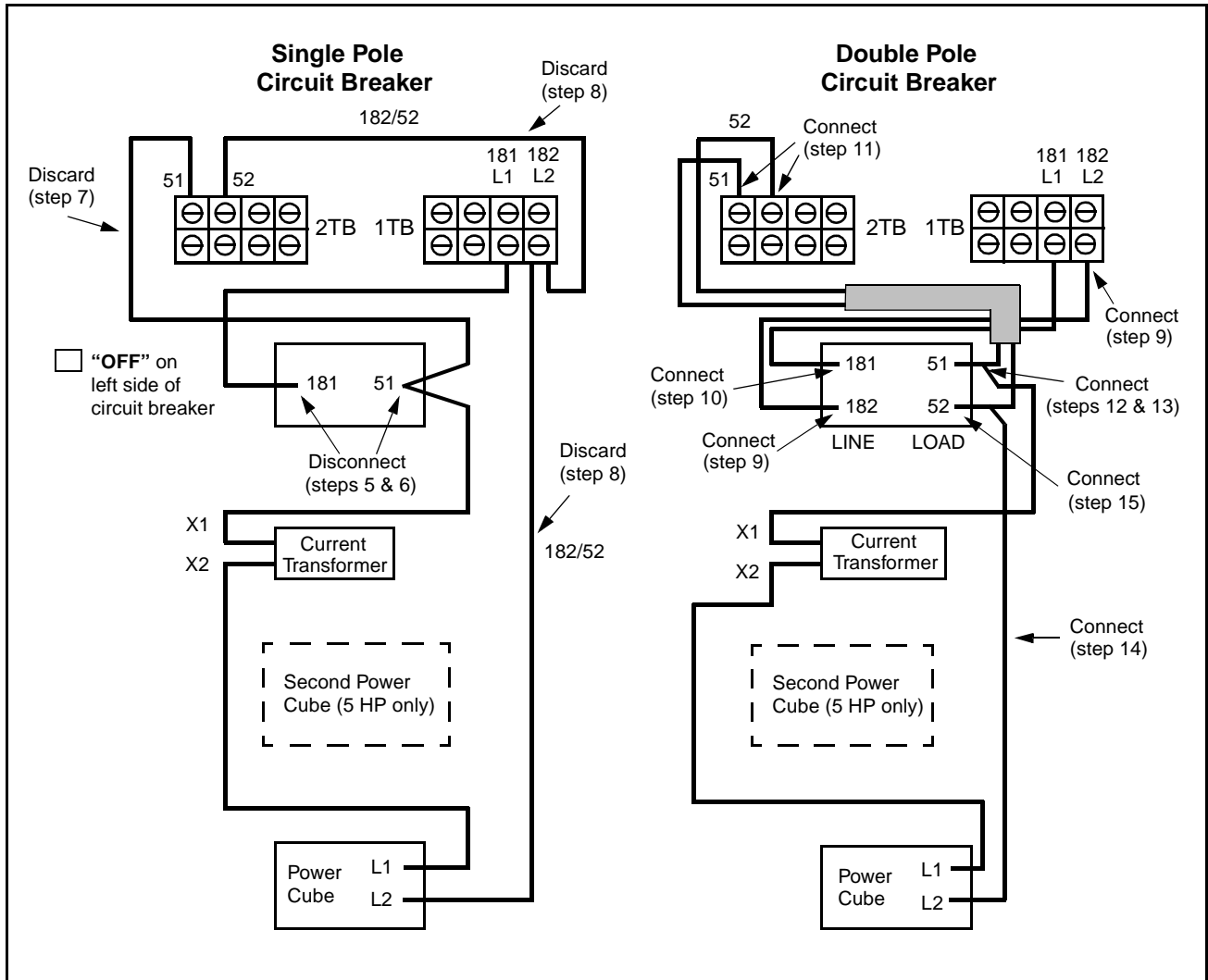

Figure 1 – Wiring the Double Pole Circuit Breaker

- Step 3. Locate the standard, factory-installed single pole circuit breaker near the top of the drive. Remove its two mounting screws and break away the metal tab on the top of the support bracket. Save the Nomex™ shield for use with the double pole circuit breaker.
- Step 4. Remove the two screws that fasten the terminal block and circuit breaker bracket to the chassis. Move the bracket aside.
- Step 5. Disconnect wire 181 from the existing breaker.
- Step 6. Disconnect both wires 51 from the existing breaker.
- Step 7. Disconnect the other end of wire 51 from 2TB and discard.
- Step 8. Remove wires 182/52 and discard. One wire 182/52 connects 1TB and 2TB. The other connects 1TB and the power cube.
- Step 9. Connect the new jumper wire 182 to the new breaker on the side labeled "LINE" and to 1TB at L2.
- Step 10. Connect wire 181 to the new breaker on the side labeled "LINE."

Step 11. Connect harness wire 51/52 to 2TB. Route behind the circuit breaker bracket.

Step 12. Connect wire 51 to the new breaker on the side labeled "LOAD."

Step 13. Connect harness wire 51 to the new breaker on the side labeled "LOAD."

Step 14. Connect jumper wire 52 between power cube terminal L2 and the new breaker on the side labeled "LOAD."

**Important:** 5 HP drives have two power cubes. On 5 HP models, connect jumper wire 52 to terminal L1 on the lower cube.

Step 15. Connect harness wire 52 to the new breaker on the side labeled "LOAD."

Step 16. Mount the Double Pole Circuit Breaker so that "OFF" is on the left side. Use the Nomex shield saved in step 3 and the four mounting screws. The Nomex shield should extend to the left of the breaker.

Step 17. Verify the wiring of the Double Pole Circuit Breaker and ensure that all connectors are securely fastened.

Step 18. Remount the terminal block and circuit breaker bracket to the drive.

Step 19. Reattach the cover to the drive.

Step 20. Turn circuit breaker on.

Step 21. Apply power. If any malfunction occurs when starting the drive, recheck all wiring.

This completes the installation of the Double Pole Circuit Breaker.

---

**Reach us now at [www.rockwellautomation.com](http://www.rockwellautomation.com)**

Wherever you need us, Rockwell Automation brings together leading brands in industrial automation including Allen-Bradley controls, Reliance Electric power transmission products, Dodge mechanical power transmission components, and Rockwell Software. Rockwell Automation's unique, flexible approach to helping customers achieve a competitive advantage is supported by thousands of authorized partners, distributors and system integrators around the world.



**Americas Headquarters**, 1201 South Second Street, Milwaukee, WI 53204, USA, Tel: (1) 414 382-2000, Fax: (1) 414 382-4444  
**European Headquarters SA/NV**, avenue Hermann Debroux, 46, 1160 Brussels, Belgium, Tel: (32) 2 663 06 00, Fax: (32) 2 663 06 40  
**Asia Pacific Headquarters**, 27/F Citicorp Centre, 18 Whitfield Road, Causeway Bay, Hong Kong, Tel: (852) 2887 4788, Fax: (852) 2508 1846

**Rockwell  
Automation**