

Quick Start Instructions

Wiring

Power Up

Parameter Setting

Reliance Electric Drives SP600 AC Variable Frequency Inverter - 1/2 to 20 HP



NEMA 4X/12 Washdown

Quick Start Instructions:
A quick reference to some basic configurations and drive features.

D-2992

OIM Keypad and Display

The built-in keypad and display allow for setup, parameter adjustment, monitoring and diagnostics.

Operator Interface Module (OIM)

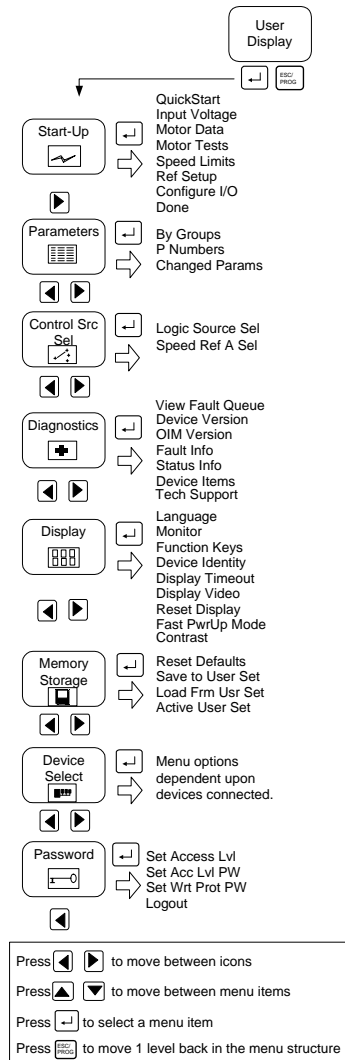

NOTE: This material is not intended to provide operational instructions. Appropriate Reliance Electric Drives instruction manuals precautions should be studied prior to installation, operation, or maintenance of equipment.

Quick Start

OIM Quick Start Menu

The Quick Start Parameters can be accessed via the keypad menu icon. Once into the selection list the following parameters can be set to configure the drive to the installed motor.

START-UP



1) QuickStart

- Stop Mode A (Ramp)
- Motor NP FLA (Drive Dependant)
- Minimum Speed (0.0 Hz)
- Maximum Speed (60.0 Hz)
- Accel. Time 1 (10.0 sec.)
- Decel. Time 1 (10.0 sec.)
- Speed Reference A select (OIM)
- Digital IN2 Select (Start)

(Defaults)

The default configuration is defined as:
 Drive Voltage rating = Motor Voltage
 Start/Stop control = OIM
 Speed Reference = OIM
 Control Mode = Sensorless Vector

If the drive default configuration is to be used for initial startup then the above parameters are the only settings required.

If the user needs to customize the drive configuration different than the default setting, then the user should verify parameter settings accessible throughout start-up menu.

2) Input Voltages

- 200/240, 400/480, and 575 VAC, based on model number

3) Motor Nameplate Data

- Motor Power Units
- Motor Power

Quick Start

3) Motor Nameplate Data cont'd

- Motor FLA
- Motor Volts
- Motor Hertz
- Motor RPM

4) Motor Tests

- Direction
- AutoTune

ATTENTION: Rotation of the motor in an undesired direction can occur during this procedure Autotune (61) = Rotate Tune (2). To guard against possible injury and/or equipment damage, it is recommended that the motor be disconnected from the load before proceeding.

5) Speed Limits

- Minimum, Maximum
- Direction Limit
- Stop Mode

6) Reference Setup

- OIM Keypad, Terminal Block, Network, Other

7) Configure I/O

- Digital Inputs/Outputs
- Analog Outputs

Control Mode

(P53) Torque Perf Mode
 Control performance can be selected from:

- Sensorless Vector (default)
Highest performance mode of control
- SV Economize
Sensorless Vector with energy saving
- Custom V/Hz
Basic open loop control. Multi-motor application
- Fan/Pump: V/Hz
Provides for a Fan load V/Hz curve

Power Wiring

Input Voltage: Determined by model number. Voltage Class configures the drive for International voltage supplies.

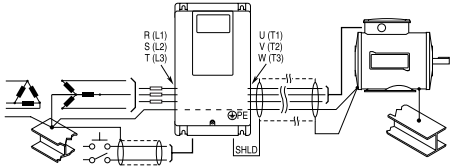

ATTENTION: The SP600 does not provide branch circuit protection. The user must install the proper protection devices.

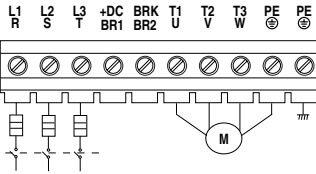

Control Wiring

Default: (Out-of-the-box) configuration is for Keypad control. The user will be able to start the controller using the built-in drive mounted operator interface module.

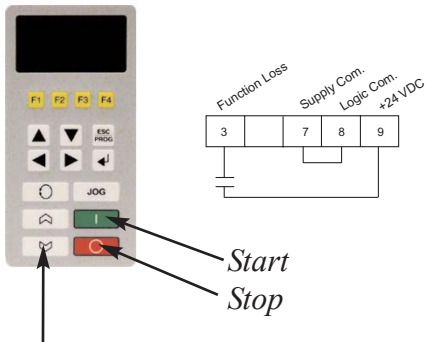

Increase / Decrease Speed

Control Wiring cont'd

Two Wire Start/Stop Control

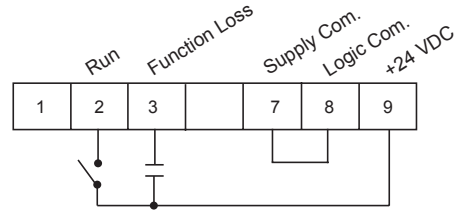

(P89) Logic Source Sel = Terminal Block
 (P361) Digital In1 Sel = Not Used
 (P362) Digital In2 Sel = Run
 (P363) Digital In3 Sel = Function Loss

Three Wire Start/Stop Control

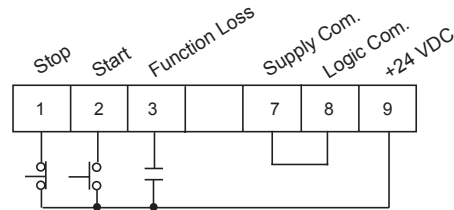

(P89) Logic Source Sel = Terminal Block
 (P361) Digital In1 Sel = Stop
 (P362) Digital In2 Sel = Start
 (P363) Digital In3 Sel = Function Loss

See Parameters P361 to P366 for configuration of all logic inputs.

Reference Wiring

Analog Reference Wiring (0 to 10 VDC Input)

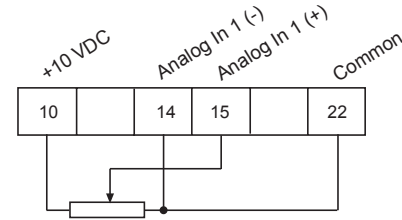

(P90) Speed Ref A Sel = Analog In1
 (P91) Speed Ref Hi = 60 Hz.
 (P92) Speed Ref Lo = 0 Hz.
 (P320) Analog In Config = ..xx00
 (P322) Analog In 1 Hi = 10.0 V
 (P323) Analog In 1 L0 = 0.0 V
 Analog Inputs can be configured for 4-20 mA. See instruction manual.

Analog Output Wiring (0 to 10 VDC Output)

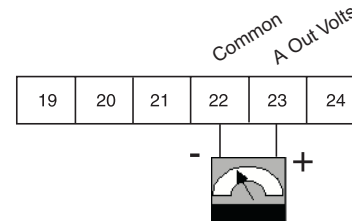

(P341) Analog Out Absolute = 1
 (P342) Analog Out1 Sel = Output Freq.
 (P343) Analog Out1 Hi = 10.0 V
 (P344) Analog Out1 Lo = 0.0 V

Terminal Assignments

Term.#	Definition	Default
1	Digital In #1	Stop/Clr Flt
2	Digital In #2	Start
3	Digital In #3	Function Loss
4	Digital In #4	Jog
5	Digital In #5	Manual
6	Digital In #6	Speed Sel 1
7	+24VDC Int. Common	Logic
8	Logic Input Common	Input Supply
9	+24VDC Output	Terminals
10	+10VDC Ref. Supply	
11	Relay Out #1 - NO	
12	Relay Out #1 - C	/Fault*
13	Relay Out #1 - NC	
14	Analog In #1 Volts (-)	Not
15	Analog In #1 Volts (+)	Assigned
16	Analog In #1 (4-20ma)	Default 4-20 mA
17	Analog In #1 (4-20ma)	Input
18	Analog In #2 Volts (-)	Default 0-10 VDC
19	Analog In #2 Volts (+)	Input
20	Analog In #2 (4-20ma)	Not
21	Analog In #2 (4-20ma)	Assigned
22	Analog Common	Analog Output
23	Analog Out Volts (+)	Output Freq. (Hz)
24	Relay Out #2 - NO	
25	Relay Out #2 - C	Running*
26	Relay Out #2 - NC	

* Form C Relay contact outputs:
 NO (Normally Open)
 NC (Normally Closed)
 C (Common)