

LISTEN.
THINK.
SOLVE.®

Applying EtherNet/IP and Stratix Switches in Real-Time Manufacturing Applications

Why EtherNet/IP?

EtherNet/IP is...

- Standard
 - EtherNet/IP is an open standard, unmodified (IEEE 802.x) Ethernet (ODVA)
- Established
 - Since 2001 Rockwell Automation has more than 3.0M Ethernet/IP nodes installed in the field. **Largest Industrial Ethernet Network to date has 3400 Nodes.**
- More than a Fieldbus
 - Control your machinery, supervise your factory, and manage your enterprise with just one network



EtherNet/IP = Standard Ethernet

Standard

EtherNet/IP

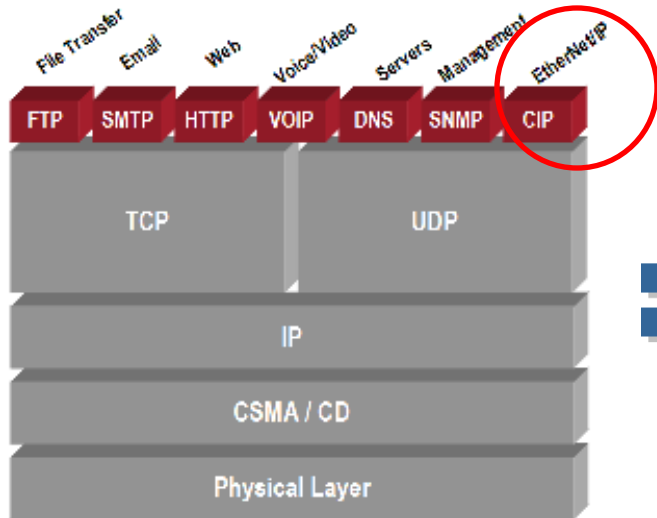

= STANDARD

Competitive Ethernet

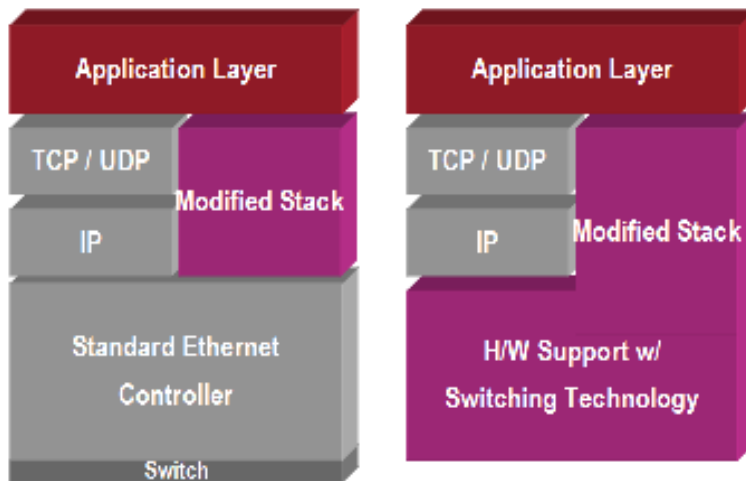

= NON-STANDARD

Manufacturing Network Convergence

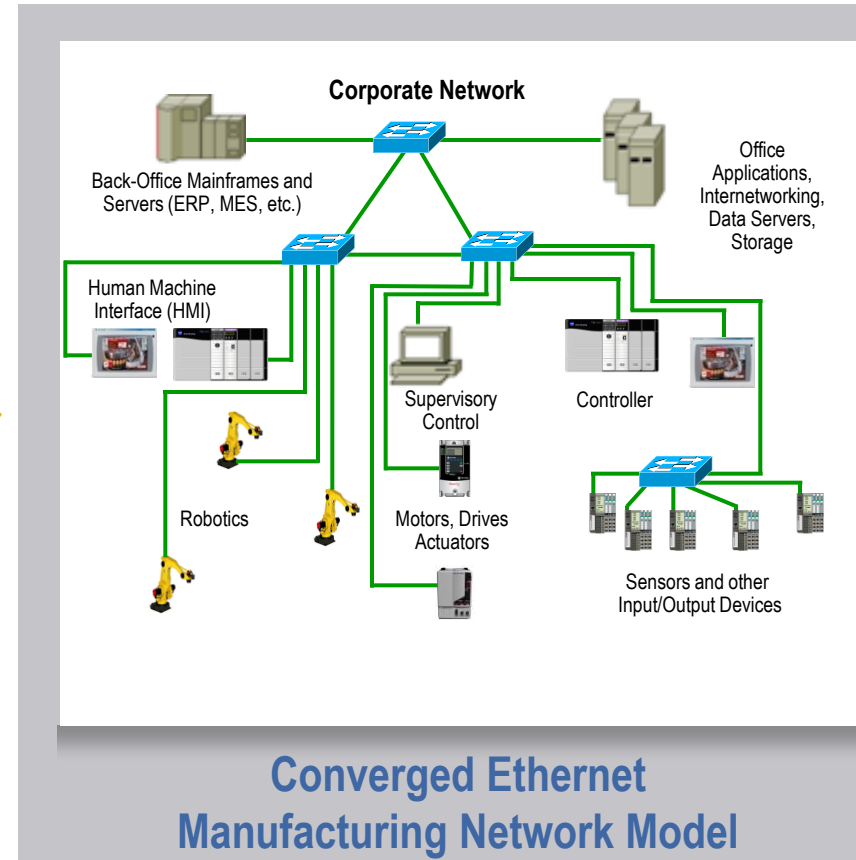
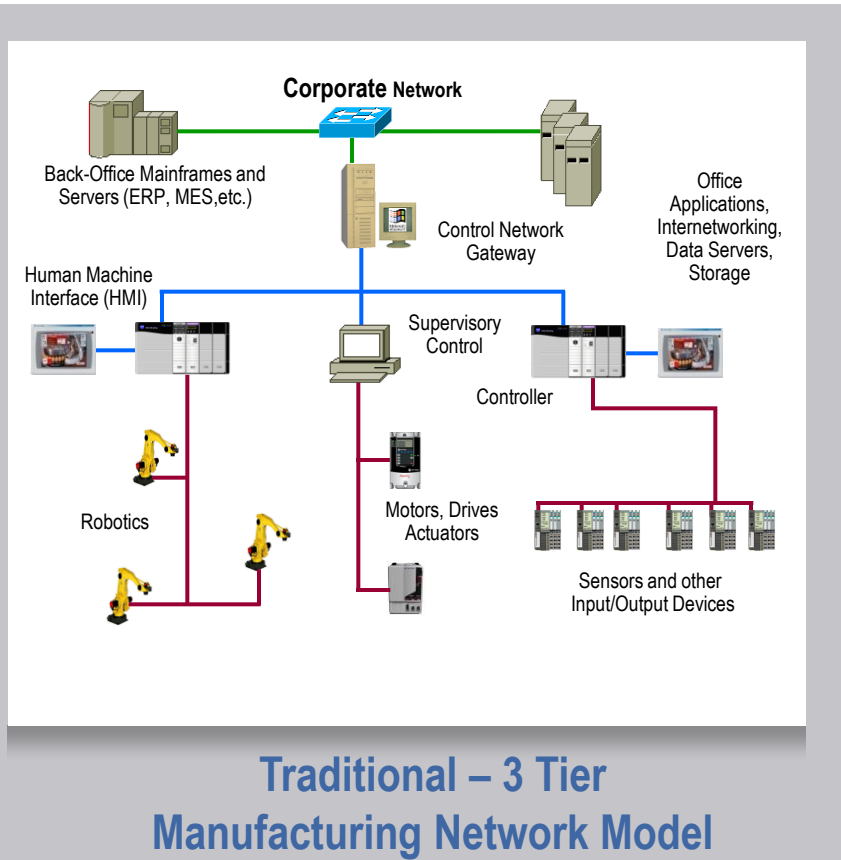

Convergence of Control and Information

The Stratix Family



Integrating manufacturing and enterprise environments



Stratix 8000

Modular Managed

- 6 to 26 port configurations
- Layer 2 and Layer 3 switching and routing
- Features designed for IT, Controls and Manufacturing professionals
 - Cisco Technology Inside:
 - IOS, CLI, CNA - Common Tools with Cisco Catalyst
 - RSLogix 5000 Add-On-Profile:
 - CIP enabled for premier integration into RA Integrated Architecture with Logix tags & FactoryTalk View faceplates
 - CompactFlash – Stores IOS and switch configuration for easy device replacement





Optimized for Plant floor and Enterprise Integration



Stratix 6000

Entry Level Fixed Managed

- 4 and 8+1 Port configurations
- Features designed for integration of EtherNet/IP devices for machine control
 - RSLogix 5000 Add-On-Profile:
 - CIP enabled for premier integration into RA Integrated Architecture with Logix tags & FactoryTalk View faceplates



For monitoring & controlling distributed devices



Stratix 2000

Unmanaged

- 4 to 8 Fiber & Copper available Port configurations
- Designed for cost effective device level systems



Small & isolated networks



2 port Switch

Embedded Switch Technology

- 2 port technology embedded into machine level devices
- Designed to simplify network design & deployment, and reduce costs
 - Supports linear and high performance ring topologies (<3msec)
 - Diagnostics, QoS, IGMP and 1588 PTP enabled
 - Open standard (ODVA) for 3rd party compatibility



Simplifies network design and deployment

A family of unique, scalable industrial Ethernet switches
From plant floor to enterprise level applications

Rockwell Automation Stratix 8000/ 8300 Managed Switches with Cisco Technology

Best of Cisco

- Secure integration with enterprise network
 - Cisco internetworking operating system (IOS™)
 - Cisco Catalyst™ switch architecture and feature set
 - Familiar tools for IT professionals: command line interface (CLI), Cisco Network Assistant (CNA) and Device Manager



Best of Rockwell Automation



- Premier (CIP) interface to Integrated Architecture
 - RSLogix 5000 for configuration (AOP)
 - Predefined Logic tags for diagnostics
 - FactoryTalk View Faceplates



Best for the Plant Floor Environment

- Easy to Integrate and Maintain
 - Default configurations for Industrial Automation market (Globals and Smartports)
 - Removable Compact Flash for one step device replacement



Integrating the Enterprise and Manufacturing Environments

Stratix 5700

- 3 fixed port configurations w/ 20 new SKUs
 - 6 port (2 versions)
 - 6 copper ports
 - 4 copper ports +2 SFP slots
 - 10 ports
 - 8 copper ports + 2 combo ports (copper or SFP slots)
 - 20 ports
 - 16 copper +2 combo ports +2 SFP slots
- Optional features include:
 - Fiber SFP for multimode, singlemode and long haul
 - 2 Gig ports
 - 1588 support
 - Network Address Translation (NAT) – Phase 2
 - Conformal Coating for extreme environments
- 2 Software Options
 - Lite: ideal for small or isolated machines
 - Full: fully featured for machines that tightly integrate with the enterprise



Stratix 5700 Hardware Features

- Dual power inputs
 - 12V DC, 24V DC, 48V DC power
- Alarm Relay
 - 24V configurable alarm inputs (2) and output
- Console port
 - Serial and USB port for device start-up and configuration
- SD flash card
 - Stores configuration and IOS of switch
- Dual ground contacts
- Din rail mount
- Temperature
 - -40 C to 60 C Operating

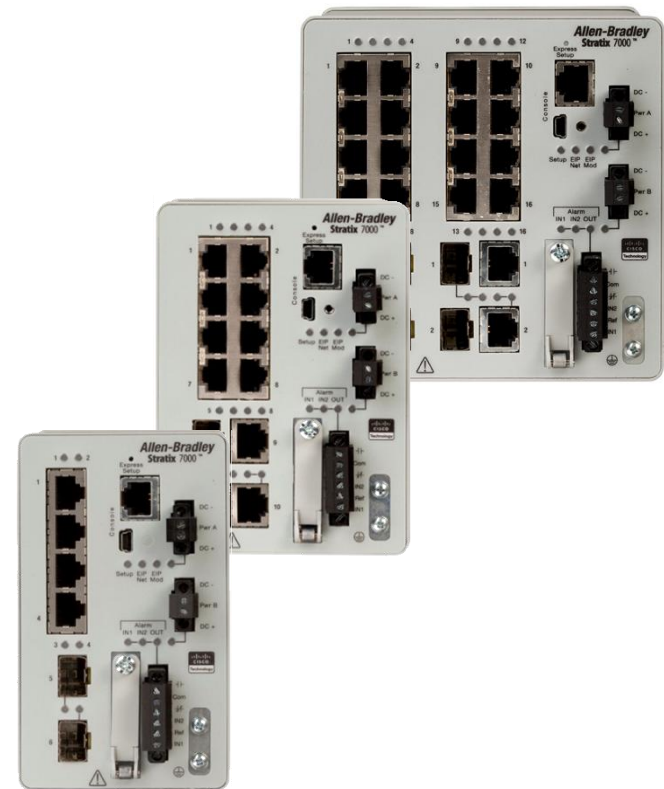

Dimensions	
6 Port	5.1"H, 2.95"W, 4.3"D
10 port	5.1"H, 3.6"W, 4.3"D
10 port w/1588+NAT	5.1"H, 3.6"W, 5.05"D
20 port	5.1"H, 5.0"W, 5.05"D

2-Port Embedded Switch Technology

- Enables Linear and Ring topologies for EtherNet/IP devices
- Network traffic is prioritized to ensure timely delivery of critical data
 - Ring recovery time is less than 3ms (worst case) for a 50 node device ring.
 - 1588 transparent clock support ensures tight synchronization for CIP Motion and CIP Sync applications.
 - Supports quality of service (QoS) and IGMP
- Open standard (ODVA) allows 3rd party suppliers to develop compatible products

Device-Level Linear

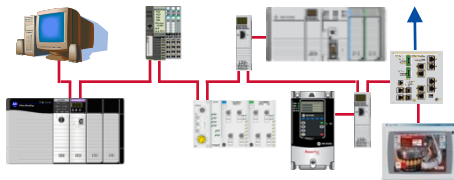

- Linear EtherNet/IP topology greatly extend the length of the application
- No need to run cables from each device back to a centralized switch

Device-Level Ring (DLR)

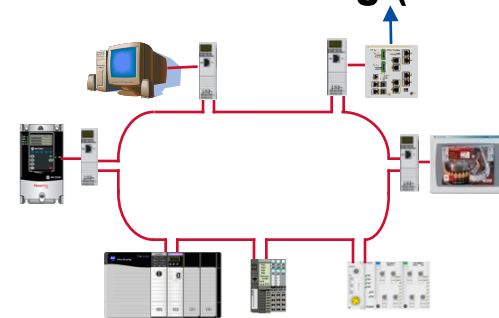

- Single fault tolerant topology provides resiliency
- Device-level ring requires no additional hardware to implement

Linear Topology

Star

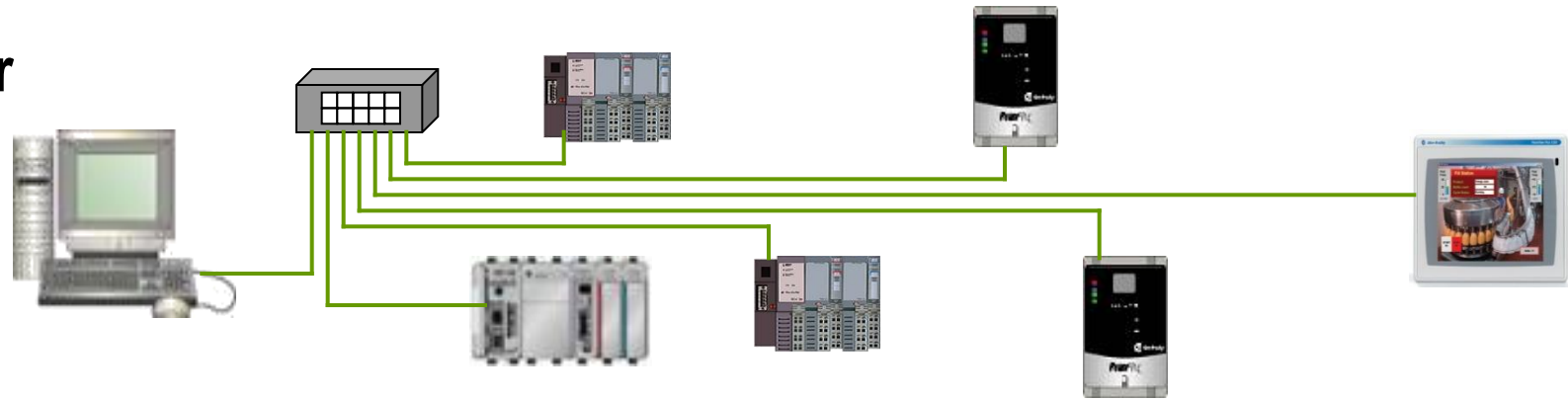

Linear

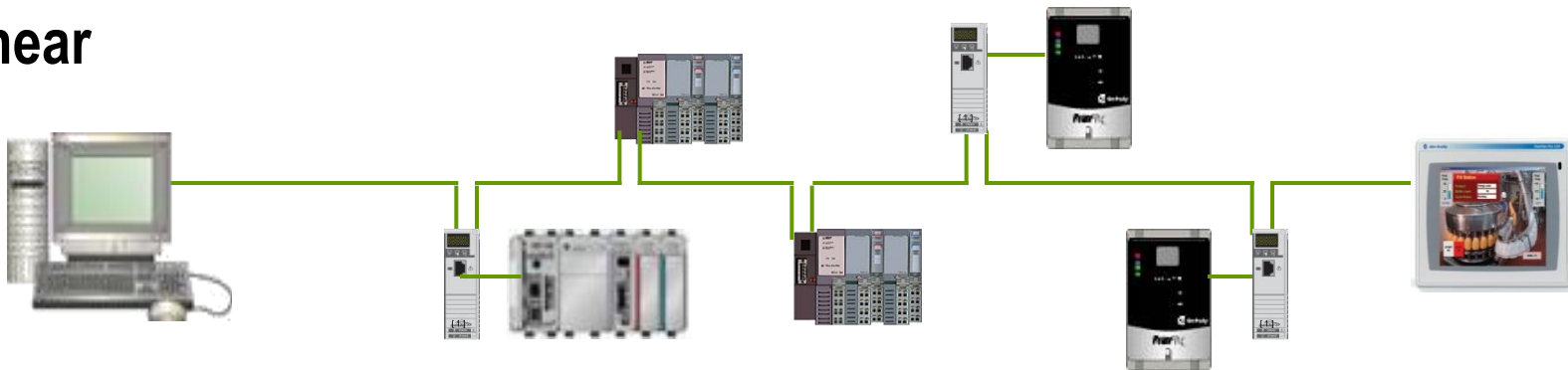

Ideal applications include:

- Application covering more than 100 meters
- Migration from field bus network

Device Level Ring Topology (DLR)

Ideal applications include:

- Low cost resiliency requirement
- Migration from field bus networks
- CIP motion and CIP sync

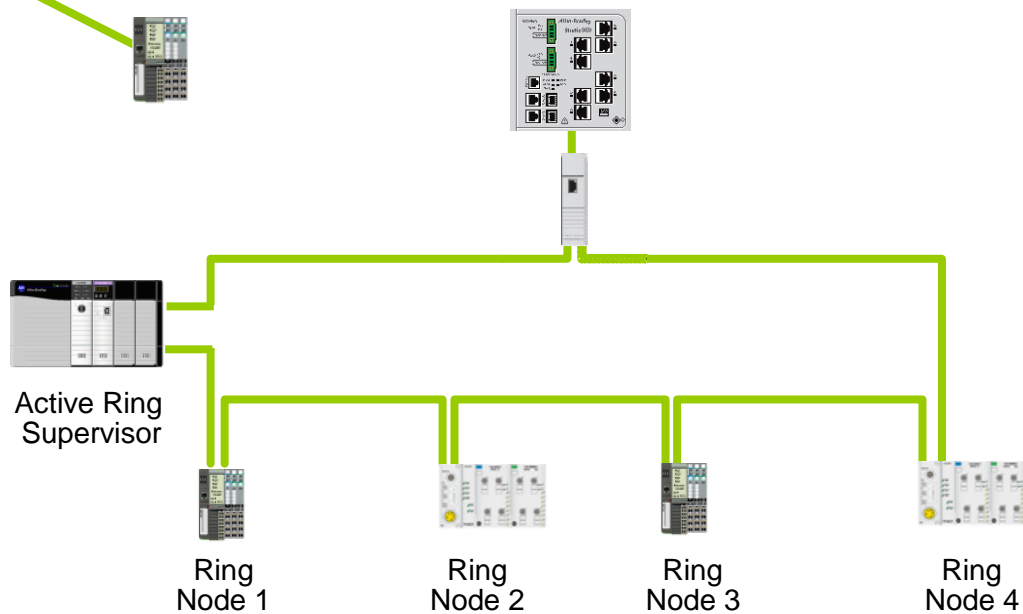
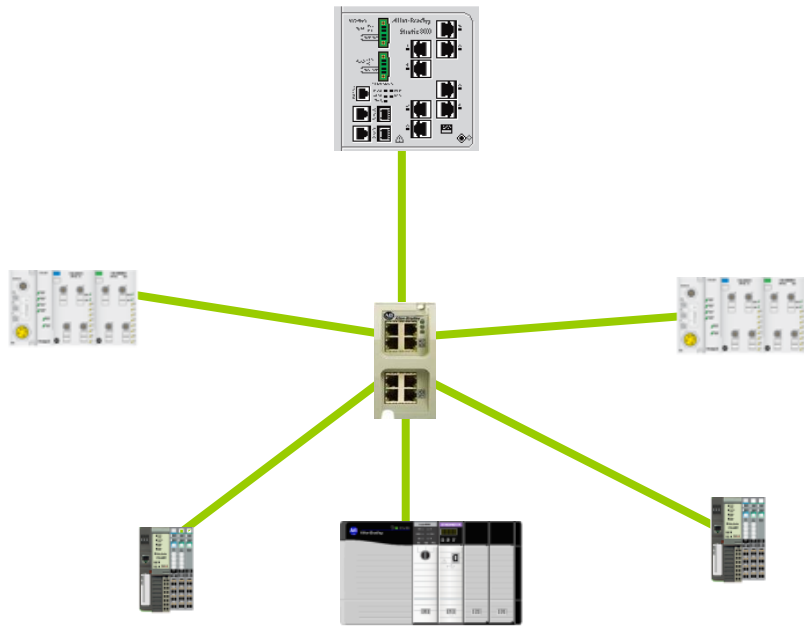

How does DLR work?

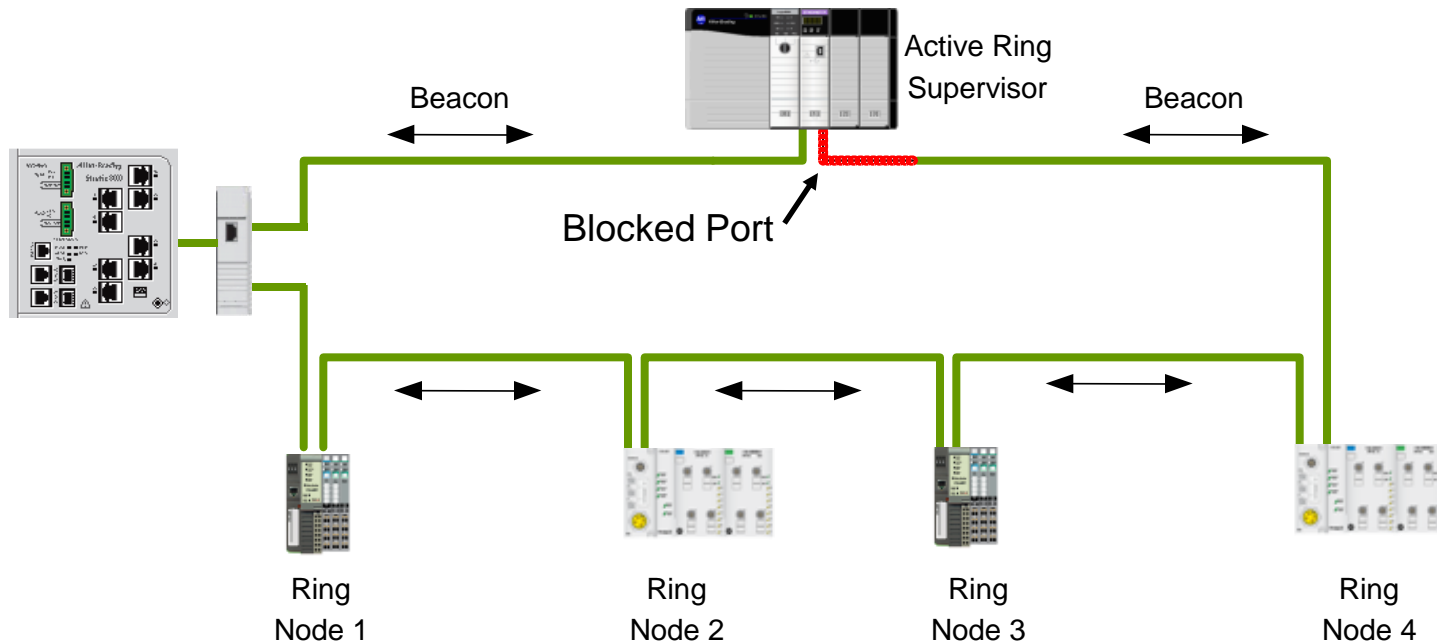

- Supervisor blocks traffic on one port
- Sends Beacon frames out both ports to detect break in the ring

Physical Layer failure

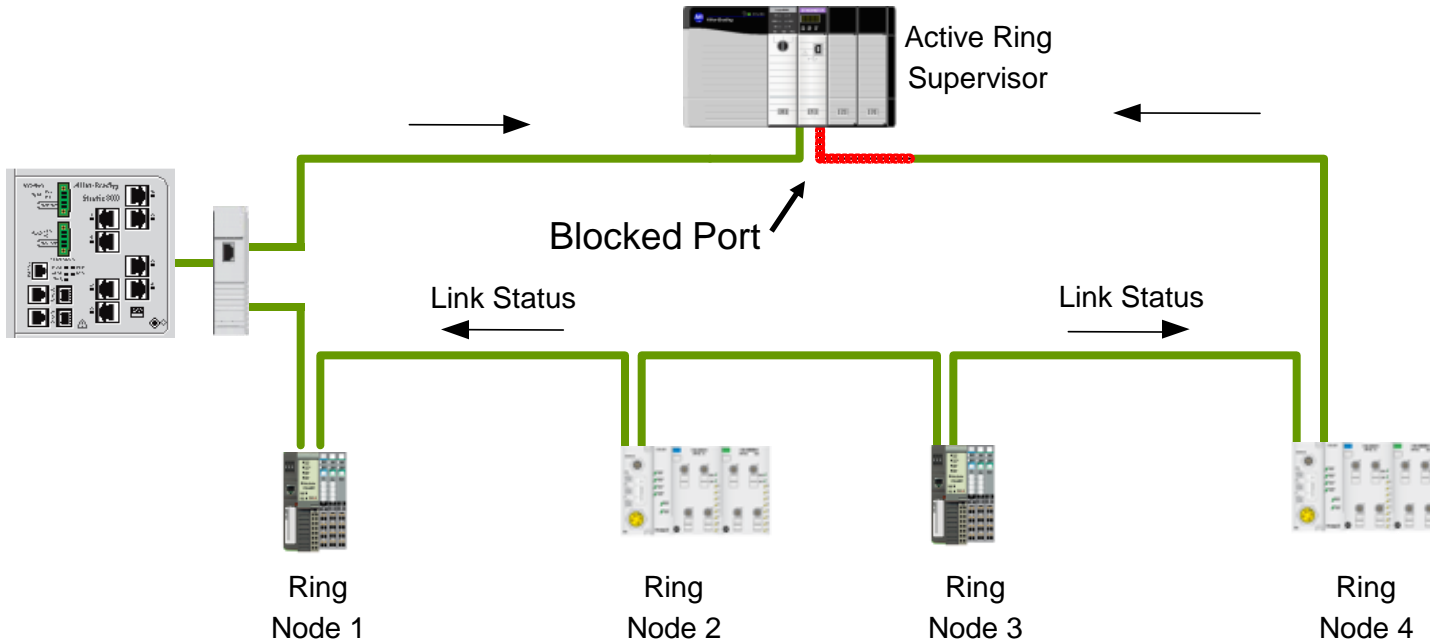

- Link Status messages are sent from the surrounding ring nodes to the ring supervisor to indicate the location of the break. Link Status is in the form of MAC ID and IP Address information.

Configuration after link failure

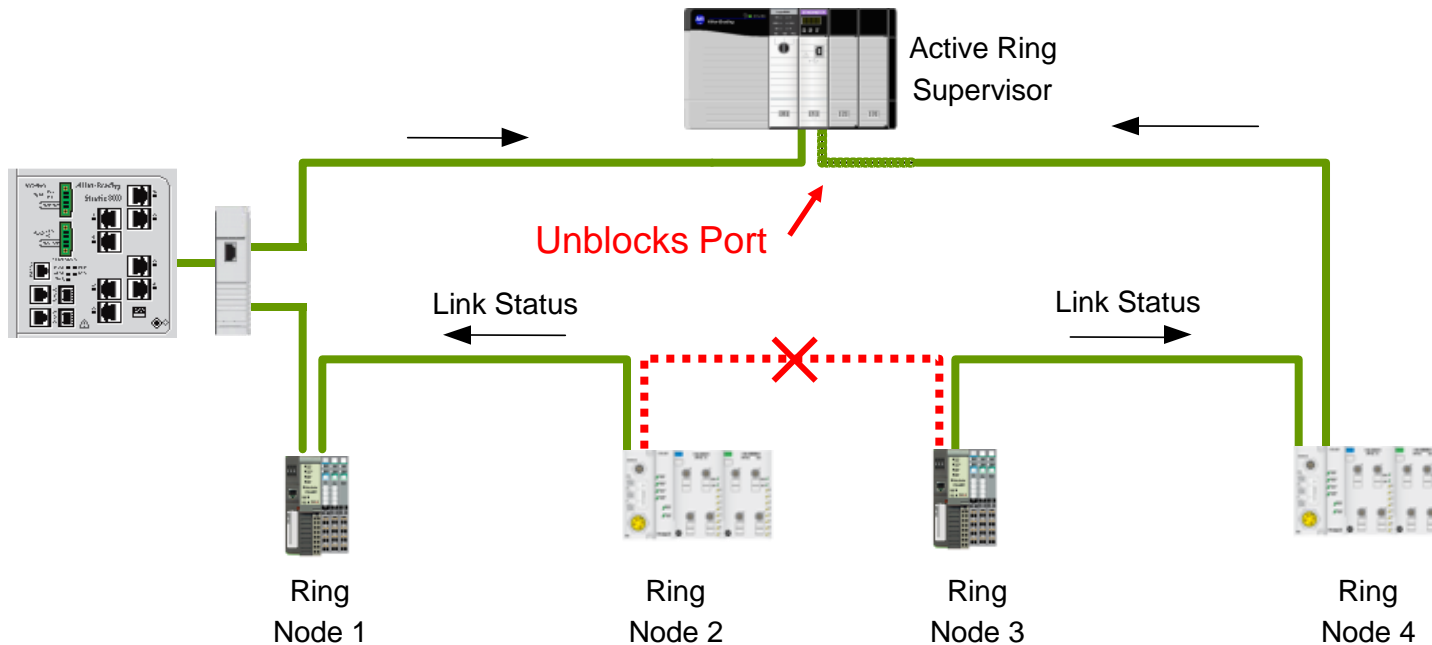

- After failure ring supervisor unblocks one port
- Network configuration is now a linear topology (faulted ring)
- Fault location is readily available
- If ring is restored, supervisor hears beacon on both ports, and transitions to normal ring mode

DLR Faceplate for FTVIEWSE

Device Level Ring (DLR)

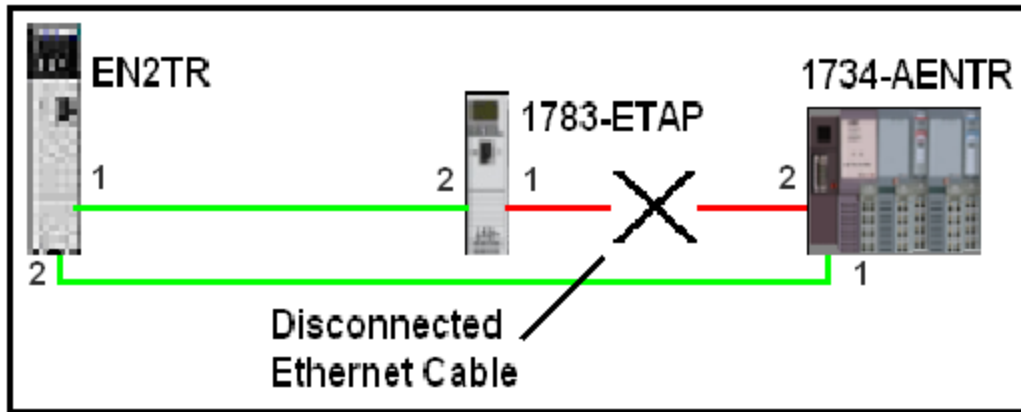

E/IP DLR Network Diagnostics

Ring Participants

Device Level Ring - Network Status Overview

Network Status: Normal

Participant Count: 3

Fault Count: 0

Reset Count

Ring Supervisor Information

Ring Supervisor: 1756-EN2TR

IP: 192.168.1.8

MAC: 00:00:BC:5C:11:64

Precedence: 0

Port Status

- Displays how many nodes are participating in the DLR Ring.
- Displays how many total rings faults there have been.
- Displays who is the DLR Ring Supervisor
- Also displays where the break is in the Ring for ease of troubleshooting.

Now shipping with DLR technology

- ControlLogix EtherNet/IP module
 - 1756-EN2TR
 - 1756-EN3TR
- EtherNet/IP Tap (ETAP) enables single-port Ethernet to join linear or ring topology (PF drive, PV+, etc.)
 - 1783-ETAP – 2 port copper
 - 1783-ETAP1F – 1 port copper 1 port fiber
 - 1783-ETAP2F – 2 port fiber
- Point I/O Adapter (1734-AENTR)
- ArmorPoint I/O Adapter (1738-AENTR)
- ArmorBlock I/O (1732E) – several versions
- Kinetix 6500 control modules – several versions
- CompactLogix L3y controllers (v20)



Ring supervisor products – need at least one to establish device-level ring

V18 & Higher: Time Synchronization (CIP Sync/ Motion)

- Devices that support CIP Sync/ Motion:

- **Now Shipping**

- (1756-L6x/ L7x) CLX Controllers
- (1756-EN2T/ EN3T(R)) CLX Ethernet Scanners
 - Transparent/ Boundary Clock Mode Capabilities
- (1756-IB16ISOE) Sequence of Event CLX I/O
- (1732E-IB16SOEM12DR) ArmorBlock I/O
 - Transparent Clock Mode Capabilities
- (1783-MS10T) Stratix 8000 Ethernet Switch
 - Transparent/ Boundary Clock Mode Capabilities
- (1783-ETAP) EtherNet/IP Tap
 - Transparent Clock Mode Capabilities
- Kinetix 6500 Drive
 - Transparent Clock Mode Capabilities
- PowerFlex 755 Drive

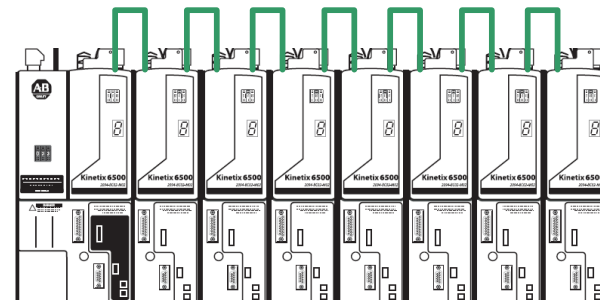

V18 & Higher: Time Synchronization (CIP Sync/ Motion)

- Gives us System-wide synchronization for CIP-based Networks
 - CIP Sync™ = CIP Network + IEEE-1588
 - Implementation of IEEE-1588 on EtherNet/IP Networks
- IEEE- 1588PTP (Precision Time Protocol)
 - “Standard for a Precision Clock Synchronization Protocol for Networked Measurement and Control Systems”
 - “Precision Time Protocol” (PTP) defined by standard.
 - Nanosecond resolution
 - +/- 100 nanosecond synchronization (Hardware assist clock)
- Advantages:
 - Minimal installation and administration
 - Wide spectrum of clock accuracy
 - Low cost, high precision

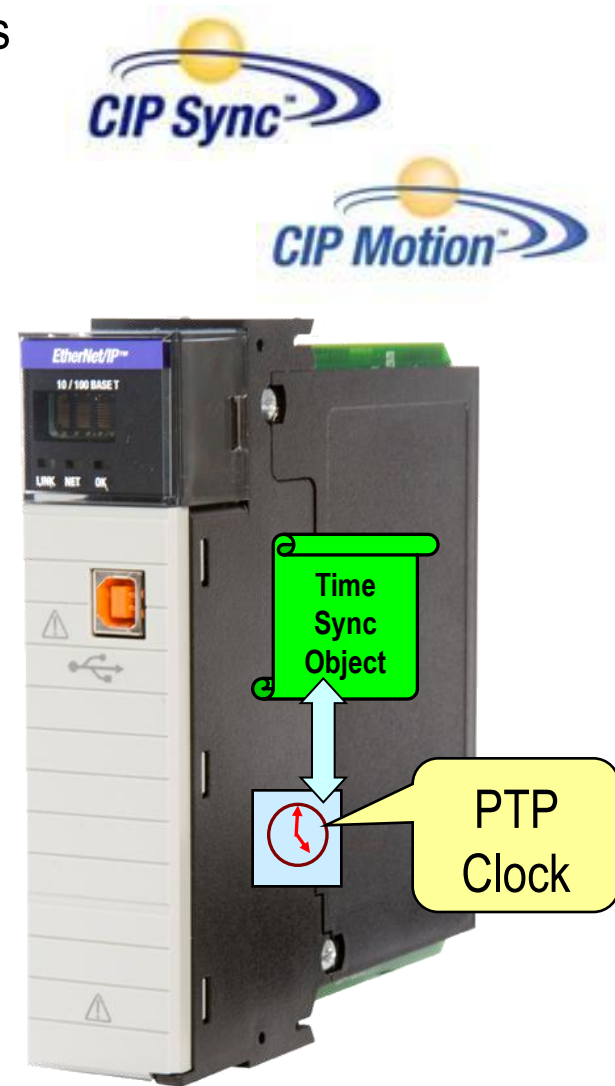

Lab Agenda

- Lab 1 – Stratix 8000 hardware familiarization
- Lab 2 – Configuring a Stratix 8000 switch and Flex I/O on an Ethernet/IP network
- Lab 3 – Stratix 8000 AOI and Diagnostic Faceplates
- Lab 4 – Device Level Ring (DLR) Topology
- Lab 5 – **(Optional)** System Time Synchronization using CIP Sync/ SOE

Lab should take about 1hour and 20 minutes to complete without optional section. Only start Lab 5 if you have approximately 30 minutes.

LISTEN.
THINK.
SOLVE.®

Thank you for participating!