

Specifications LC-200-XXX



Performance Parameters	Symbol	Units	LC-200-100			LC-200-200			LC-200-300			LC-200-400			LC-200-600			LC-200-800																				
			NC	AC	WC	NC	AC	WC	NC	AC	WC	NC	AC	WC	NC	AC	WC	NC	AC	WC																		
Cooling Method			NC	AC	WC	NC	AC	WC	NC	AC	WC	NC	AC	WC	NC	AC	WC	NC	AC	WC																		
Continuous Force ¹	F _{cTmax}	N (lbf)	448 (101)	560 (126)	672 (151)	897 (202)	1121 (252)	1345 (302)	1344 (302)	1680 (378)	2015 (453)	1792 (403)	2239 (503)	2687 (604)	2687 (604)	3359 (755)	4031 (906)	3583 (806)	4479 (1007)	5375 (1208)																		
Peak Force ²	F _p	N (lbf)	1107 (249)	1107 (249)	1107 (249)	2214 (498)	2214 (498)	2214 (498)	3318 (746)	3318 (746)	3318 (746)	4424 (995)	4424 (995)	4424 (995)	6637 (1492)	6637 (1492)	6637 (1492)	8849 (1989)	8849 (1989)	8849 (1989)																		
Motor Constant ¹	K _M	N/√W (lbf/√W)	35.6 (8.0)	35.6 (8.0)	35.6 (8.0)	50.3 (11.3)	50.3 (11.3)	50.3 (11.3)	61.5 (13.8)	61.5 (13.8)	61.5 (13.8)	71.1 (16.0)	71.1 (16.0)	71.1 (16.0)	87.0 (19.6)	87.0 (19.6)	87.0 (19.6)	100.5 (22.6)	100.5 (22.6)	100.5 (22.6)																		
Thermal Resistance	R _{th}	°C/W	0.69	0.44	0.31	0.35	0.22	0.15	0.23	0.15	0.10	0.17	0.11	0.08	0.12	0.07	0.05	0.09	0.06	0.04																		
Max Power Dissipation	P _{cTmax}	W	159	248	358	318	497	715	477	745	1073	636	993	1430	954	1490	2146	1272	1987	2861																		
Maximum Applied Bus Voltage ⁷	V _{DC}	Volts	650			650			650			650			650			650																				
Electrical Cycle Length	E _c	mm	50			50			50			50			50			50																				
Electrical Time Constant	τ _e	msec	10			10			10			10			10			10																				
Maximum Coil Temperature	T _{max}	°C	130			130			130			130			130			130																				
Winding Type			D		E	D		E	D		E	D		E	D		E	D		E																		
Force Constant ^{1,6}	K _F	N/A _{pk} (lbf/A _{pk})	121.3 (27.3)		N/A	121.3 (27.3)		242.7 (54.6)	121.3 (27.3)		364.0 (81.8)	121.3 (27.3)		242.7 (54.6)	121.3 (27.3)		242.7 (54.6)	121.3 (27.3)		242.7 (54.6)																		
Back EMF Constant p-p ^{3,4,6}	K _e	V _p /m/s (V _p /in/s)	143.3 (3.64)		N/A	143.3 (3.64)		286.6 (7.28)	143.3 (3.64)		430.0 (10.92)	143.3 (3.64)		286.6 (7.28)	143.3 (3.64)		286.6 (7.28)	143.3 (3.64)		286.6 (7.28)																		
Peak Current ⁴	I _p	A _{pk} (A _{rms})	10.7 (7.6)		N/A	21.5 (15.2)		10.7 (7.6)	32.2 (22.7)		10.7 (7.6)	42.9 (30.3)		21.4 (15.2)	64.3 (45.5)		32.2 (22.7)	85.8 (60.7)		42.9 (30.3)																		
Cooling Type			NC	AC	WC	NC	AC	WC	NC	AC	WC	NC	AC	WC	NC	AC	WC	NC	AC	WC	NC	AC	WC	NC	AC	WC	NC	AC	WC	NC	AC	WC						
Continuous Current ^{1,4}	I _{cTmax}	A _{pk} (A _{rms})	3.7 (2.6)	4.6 (3.3)	5.5 (3.9)	N/A	N/A	N/A	7.4 (5.2)	9.2 (6.5)	11.1 (7.8)	3.7 (2.6)	4.6 (3.3)	5.5 (3.9)	11.1 (7.8)	13.8 (9.8)	16.6 (11.7)	3.7 (2.6)	4.6 (3.3)	5.5 (3.9)	14.8 (10.4)	18.5 (13.1)	22.1 (15.7)	7.4 (5.2)	9.2 (6.5)	11.1 (7.8)	22.1 (15.7)	27.7 (19.6)	33.2 (23.5)	11.1 (7.8)	13.8 (9.8)	16.6 (11.7)	29.5 (20.9)	36.9 (26.1)	44.3 (31.3)	14.8 (10.4)	18.5 (13.1)	22.1 (15.7)
Resistance p-p ^{3,6} @20°C	R ₂₀	ohm	10.84		N/A	5.42		21.68	3.62		32.58	2.72		10.86	1.81		7.24	1.36		5.43																		
Inductance p-p ³	L	mH	111.6		N/A	55.8		223	37.20		335	28		112	19		74	14		56																		
Mechanical Parameters																																						
Magnetic Attraction ⁸	F _a	N (lbf)	2620 (589)			5240 (1178)			7860 (1767)			10480 (2356)			15720 (3534)			20960 (4712)																				
Coil Mass ⁵	M _c	kg (lb _m)	5.74 (12.7)	6.83 (15.1)	6.83 (15.1)	9.98 (21.8)	11.79 (26.0)	11.79 (26.0)	14.04 (30.9)	16.76 (36.9)	16.76 (36.9)	18.19 (40.1)	21.72 (47.9)	21.72 (47.9)	26.79 (59.1)	31.92 (70.4)	31.92 (70.4)	35.23 (77.7)	42.03 (92.7)	42.03 (92.7)																		
Magnetic Track Mass	M _n	kg/m (lb/in)	20.93 (1.18)			20.93 (1.18)			20.93 (1.18)			20.93 (1.18)			20.93 (1.18)			20.93 (1.18)																				

Notes: NC= No Cooling, AC= Air Cooling, WC = Water Cooling

Motor performance specifications are with sinusoidal commutation.

- Continuous forces, motor constant and current listed are with coils at maximum temperature 130°C, mounted to a 1" aluminum heat sink whose area is noted in the table, and at 20°C ambient.
- Max on time 1 sec. In certain applications, the motor may produce significantly higher peak forces. Please contact Anorad Applications Engineering for details.
- All winding parameters listed are measured line-to-line (phase-to-phase).
- All currents and voltages listed are measured 0-peak of the sine wave unless noted rms.
- AC and WC include mass of cooling plate. Consult Anorad for Flow and Pressure for air cooled and water cooled version.
- All specifications are ±10%. Phase-to-phase inductance is ±30%.
- Maximum cable length 10 meters. Please consult factory concerning applications requiring longer cables.
- All specifications are at the standard referenced air gap.

Motor Phasing Diagram

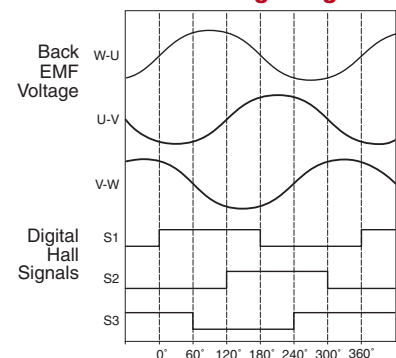

Note: Phasing direction is coil moving towards motor power cable.

Coil Assembly LC-200-XXX

Dimensions mm [in]

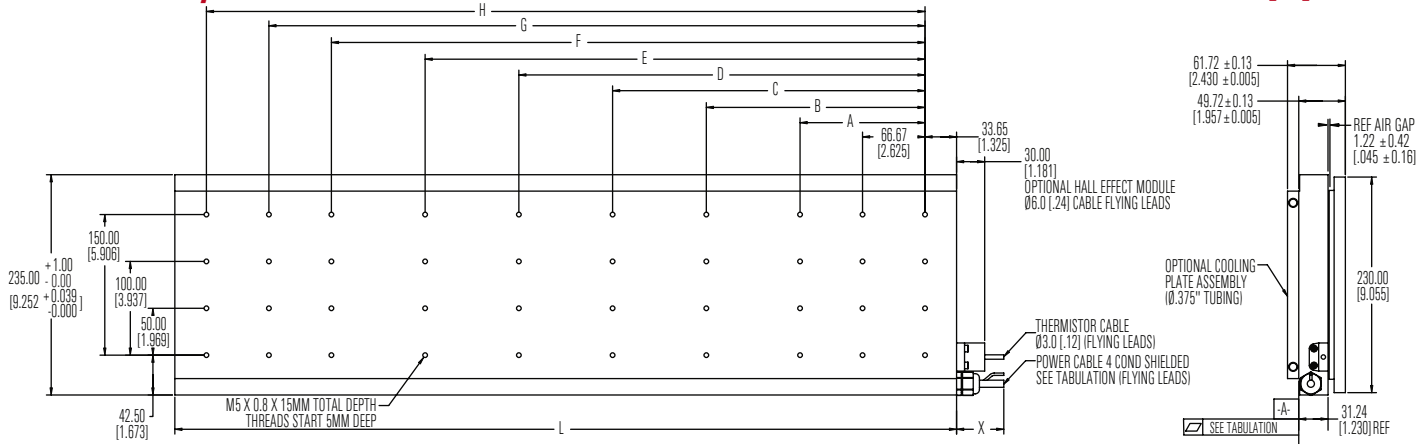

Cooling Plate LCCP-200-XXX

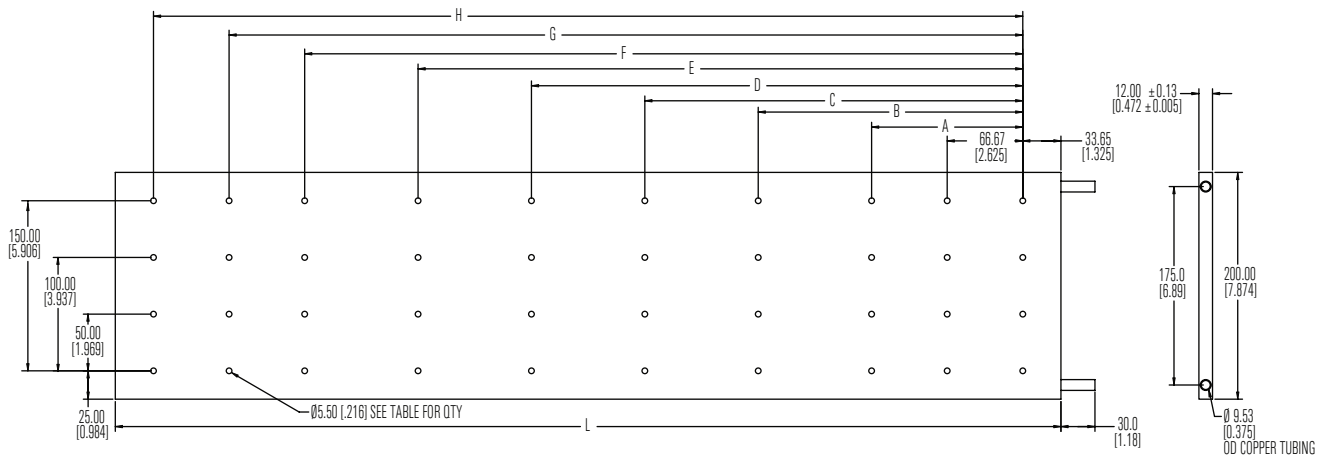

Coil and Cooling Plate Dimensions												
Coil Size	L	A	B	C	D	E	F	G	H	Hole Qty (N)	Flatness -A-	Heat Sink
200 x 100	134.00 (5.28)									8	0.25 (0.010)	500 x 200 (20 x 8)
200 x 200	234.00 (9.21)	100.00 (3.937)	166.67 (6.562)							16	0.25 (0.010)	500 x 300 (20 x 12)
200 x 300	334.00 (13.15)	133.33 (5.249)	200.00 (7.874)	266.67 (10.499)						20	0.38 (0.015)	500 x 400 (20 x 16)
200 x 400	434.00 (17.09)	133.33 (5.249)	233.33 (9.186)	300.00 (11.811)	366.67 (14.436)					24	0.64 (0.025)	500 x 500 (20 x 20)
200 x 600	634.00 (24.96)	133.33 (5.249)	233.33 (9.186)	333.33 (13.123)	433.33 (17.060)	500.00 (19.686)	566.66 (22.310)			32	0.89 (0.035)	500 x 750 (20 x 30)
200 x 800	834.00 (32.84)	133.33 (5.249)	233.33 (9.186)	333.33 (13.123)	433.33 (17.060)	533.33 (20.997)	633.33 (24.934)	700.00 (27.559)	766.66 (30.184)	40	1.16 (0.045)	500 x 1000 (20 x 40)

Power Cable Gauge		
Coil Size	Winding Type	Wire Gauge
200 x 100	D	18 GA
200 x 200	D, E	18 GA
200 x 300	D, E	18 GA
200 x 400	D, E	18 GA
200 x 600	D	16 GA
200 x 600	E	18 GA
200 x 800	D	14 GA
200 x 800	E	18 GA

Magnet Track LCM-200-XXX*

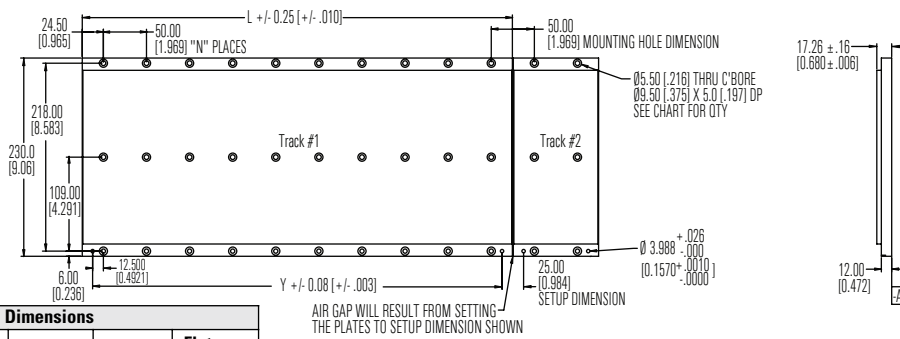

Magnet Track Dimensions					
Magnet Track Length	L	Y	Hole Qty	N	Flatness -A-TIR
100 mm	99.00 (3.90)	75.00 (2.953)	6	1	0.25 (0.010)
250 mm	249.00 (9.80)	225.00 (8.853)	15	4	0.50 (0.020)
400 mm	399.00 (15.71)	375.00 (14.764)	24	7	0.76 (0.030)
500 mm	499.00 (19.65)	475.00 (18.750)	30	9	1.0 (0.040)

* Magnet tracks can be combined for longer travel lengths.